

CSR reporting policy

We publish this report in both printed and Web versions according to the respective features of these media so as to better address the needs of our stakeholders.

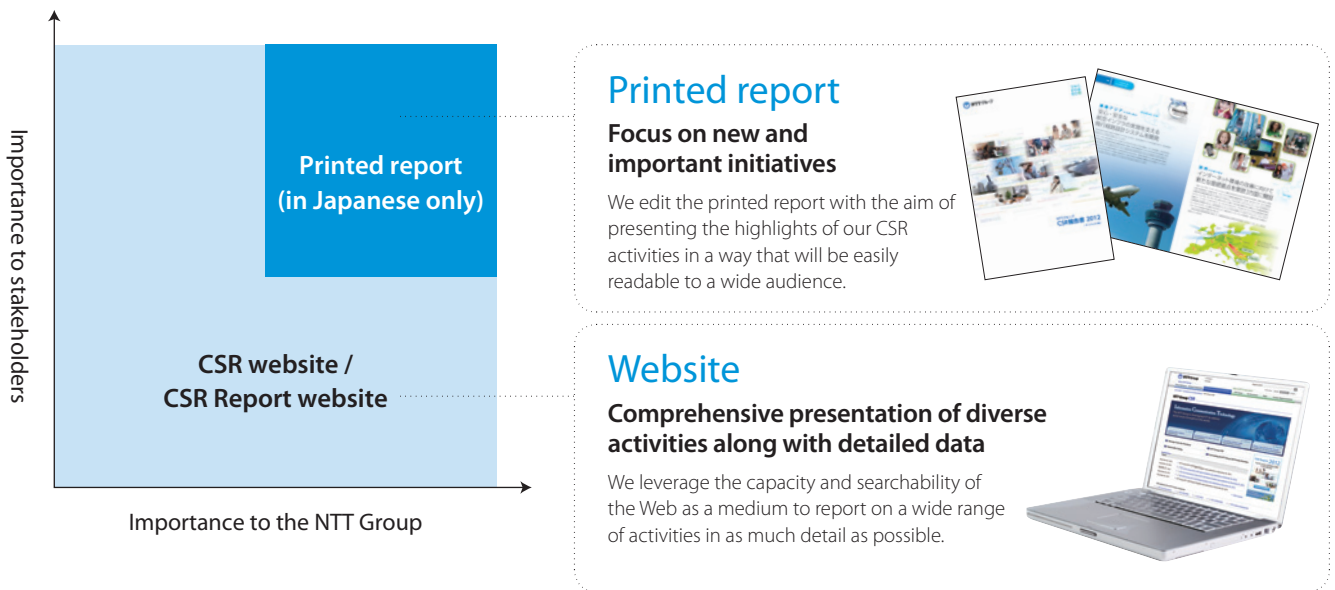

CSR website (updated as occasion demands)

We regularly update our CSR website to provide the latest information on NTT Group CSR activities in a timely fashion. The latest information can be seen in the Topics section on the top page of the site.

WEB http://www.ntt.co.jp/csr_e/

CSR Report 2012 website (updated once a year)



CSR Report 2012
(this PDF file)

The CSR Report 2012 is published in PDF format.

WEB http://www.ntt.co.jp/csr_e/2012report/

About the CSR website:

The CSR website has been designed according to NTT official homepage guidelines and evaluated by NTT CLARUTY employees with visual, hearing and other disabilities. NTT CLARUTY applied its accessibility checklist to the design of the website to help ensure that it is accessible to elderly users and people with disabilities.

CONTENTS

Based on the content of the NTT Group CSR Report website that provides a comprehensive account of our CSR activities (available in Japanese only), we publish a printed report that we position as a digest edition (available in Japanese only), and this PDF version, CSR Report 2012.

This CSR Report 2012 contains more detailed information than the printed report, packaged in an easily readable PDF format. In addition to detailed environmental data, we have included as many examples of activities as possible.

Reporting scope

Period: April 1, 2011 to March 31, 2012

- Certain activities implemented after March 31, 2012 and outlook for the future are also included.

Organization: NTT and the NTT Group companies (772 companies)

- The figures given for the NTT Group in fiscal 2012 are tabulated from figures for NTT, NTT East, NTT West, NTT Communications, NTT DOCOMO, NTT DATA and their group companies (772 companies). The scope of specific reports is noted in relevant areas.
- Organization names are current as of March 31, 2012. However, some organization names are from fiscal 2013.

Month published: December 2012

Previously published: December 2011

Next report: December 2013 (provisional)

Reference guidelines:

This report has been created with reference to the GRI (Global Reporting Initiative) Sustainability Reporting Guidelines Version 3.1 and the Ministry of the Environment's Environmental Reporting Guidelines FY2012 Version.

About the contents

- In this report, NTT refers to NIPPON TELEGRAPH AND TELEPHONE CORPORATION, NTT Group refers to NTT and its group companies, and NTT [name] refers to individual companies within the NTT Group. For the subsidiaries of major group companies other than NTT, the name of the major group company to which they belong is shown. (For example, NTT Resonant is shown as belonging to NTT Communications.)
- Should any errors be found in this report after publication, a report and table of errata will be provided on our website.
- The contents of this report refer not only to past events, but also cover future plans and forecasts at the time of publication. Such descriptions include assumptions and judgments based on information that was available at the time of printing. Please note that actual future activities and results may differ from those described herein.
- The names of services and products appearing in this report are the registered trademarks or trademarks of NTT and NTT Group companies.

1	CSR reporting policy
3	Outline of the NTT Group
5	Message from the President
7	NTT Group CSR
	Special Feature
11	I Leveraging ICT to address social issues
	Dialogue
	Maintaining and enhancing initiatives in China to contribute to the development of society and resolution of social issues
21	II Implementing the R&D required to leverage ICT
	Dialogue
	Engaging in sincere dialogue with society and creating valuable products and services that address pressing social issues
29	Follow-up report
	R&D aimed at building a robust communications infrastructure
31	Corporate governance / Ensuring compliance / Risk management system
33	Human rights awareness / Prospering with our business partners
35	R&D efforts in basic technologies / Communicating with our shareholders and investors
37	Communication between people and their communities
38	Initiatives aimed at providing ubiquitous communications
45	Initiatives to promote participation in society
47	Involvement and cooperation in public policy
48	Communication between people and the global environment
49	Environmental management
53	Creating a low carbon society
63	Implementing closed loop recycling
66	Conserving biodiversity
70	Environmental data
72	Safe and secure communication
73	Ensuring stable and reliable services as critical infrastructure
81	Ensuring information security
84	Creating a sound user environment
86	Customer satisfaction initiatives
91	Team NTT Communication
92	Promoting respect for diversity and equal opportunity
98	Creating safe and healthy workplaces
102	Citizenship activities
106	Third party opinion
107	Our response / Reader feedback

Outline of the NTT Group

Under our “Road to Service Creation Business Group” vision, we are creating and deploying ubiquitous broadband services.

Overview of the NTT Group (as of March 31, 2012)



Name: NIPPON TELEGRAPH AND TELEPHONE CORPORATION (NTT)

Head office: 3-1, Otemachi 2-chome, Chiyoda-ku, Tokyo 100-8116, Japan

Date of establishment: April 1, 1985

Common stock: ¥937.95 billion

Number of employees: 2,925 (224,239 employees on a consolidated basis)

Number of consolidated subsidiaries: 772

Website: http://www.ntt.co.jp/csr_e/
(For additional information including details of management strategy: http://www.ntt.co.jp/about_e/)

Strengths

Fortune
Global 500

29th

Moody's

Aa2

S&P

AA

Business overview

Operating revenues¹

Number of employees²

Regional communications business



Domestic intra-prefectural communications services and related ancillary services
 • Capital investments: ¥811.8 billion · R&D expenses: ¥119.5 billion
 • **Main companies:** NTT East, NTT West
 Also 84 other companies

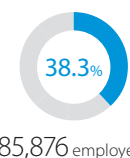
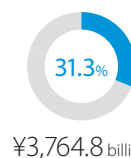

Long distance and international communications business



Domestic inter-prefectural communications services, international communications services and related ancillary services
 • Capital investments: ¥152.3 billion · R&D expenses: ¥16 billion
 • **Main companies:** NTT Communications, Dimension Data
 Also 252 other companies

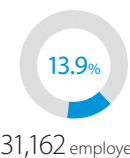
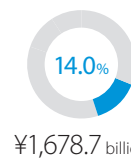

Mobile communications business



Mobile phone services and related ancillary services in Japan and overseas
 • Capital investments: ¥726.8 billion · R&D expenses: ¥108.5 billion
 • **Main companies:** NTT DOCOMO
 Also 127 other companies

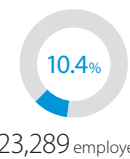
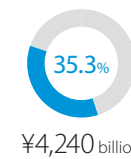

Data communications business



System integration and network system services in Japan and overseas
 • Capital investments: ¥134 billion · R&D expenses: ¥13.5 billion
 • **Main companies:** NTT DATA
 Also 222 other companies

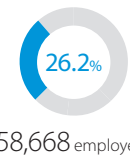
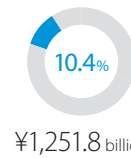

Other businesses



Real estate, finance, construction and electric power, system development and leading-edge technology development
 • Capital investments: ¥121.7 billion · R&D expenses: ¥131.4 billion
 • **Main companies:** NTT FACILITIES, NTT COMWARE, NTT Urban Development
 Also 78 other companies

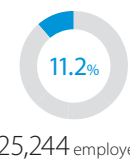

1. Percentage of the simple sum of all segments (including intersegment transactions)
 2. Percentage of total NTT Group employees

Operating revenues

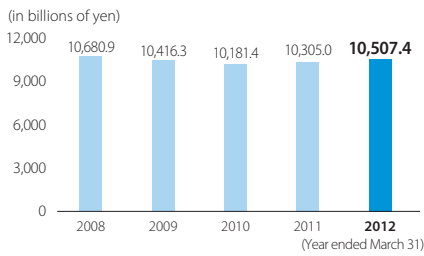

Operating income

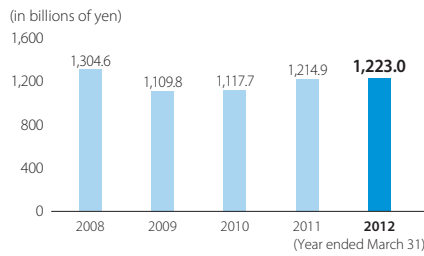

Net income

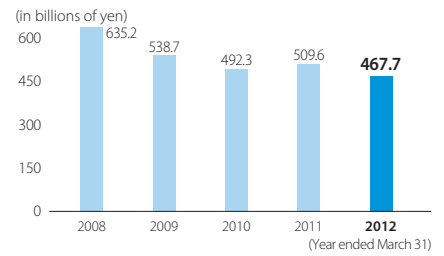

Main group companies



NTT East and NTT West provide individual and corporate customers in the East Japan and West Japan regions with a wide range of telecommunications services including fixed lines and Internet access for personal and business use. They aspire to provide stable, high quality universal services, while also pursuing fiber optic services and other solutions that contribute to local economic development.

Regional communications business



Long distance and international communications business

In addition to domestic long distance and international communications services, NTT Communications provides ICT solutions and services throughout the world, and is aiming to become a leading global ICT player.

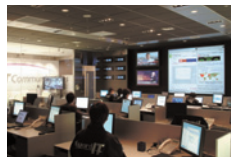

Long distance and international communications business

Dimension Data is a specialist IT services and information provider that helps clients throughout the world to plan, build, support and manage their IT infrastructures.



Mobile communications business

As a mobile communications operator, NTT DOCOMO aims to create a new communication culture through the provision of Xi (crossy), FOMA, international, satellite phone and other services.



Data communications business

As a partner for change, NTT DATA develops, provides and maintains a variety of information systems and services that support society both within Japan and overseas, and span a wide range of industries from the public sector to financial and other enterprises.



Other businesses

NTT FACILITIES provides comprehensive engineering services that combine IT, energy and construction, as well as one-stop planning, design, construction and maintenance of buildings and electrical equipment.



Other businesses

NTT COMWARE supports system aspects of building next-generation network (NGN) communications infrastructure through its three core competencies of network technology, systems and applications, and support and maintenance services.



Other businesses

NTT Urban Development focuses principally on the two areas of office space leasing and sales of its WELLITH brand of condominiums and other real estate, but is also involved in commercial facilities, rental housing, real estate solutions and other businesses.



We are working as one to fulfill our corporate social responsibility and contribute to the sustainable growth of society as we drive our evolution into a Service Creation Business Group.



Hiroo Unoura

Hiroo Unoura
President & CEO
NIPPON TELEGRAPH AND TELEPHONE CORPORATION

Earning trust as a “Value Partner”

With the growth of broadband in both fixed line and mobile communications and the rapid spread of smartphones, an increasing diversity of sophisticated services and devices are coming to the telecommunications market. Customers are also paying closer attention to the stability and reliability of telecommunications infrastructure following the Great East Japan Earthquake, and information and communications technology (ICT) is expected to play an increasingly important role in healthcare, nursing care, education,

environment, energy, security and other fields. The industry is, moreover, undergoing major changes and evolution as a result of IP-driven convergence between fixed line and mobile services, convergence between communications and broadcasting, and the leveraging of ICT to create new opportunities for growth beyond existing spheres of business, and the pace of such changes will almost certainly increase throughout the world as we move forward.

We will endeavor to drive this evolution in the ICT market and contribute to the sustainable development of society both through conducting world-class research and

development, and through building a cutting edge ubiquitous broadband environment that enables us to offer a diversity of secure, reliable and convenient services and create new business opportunities.

This is the last year of implementation of the "Road to Service Creation Business Group" Medium-Term Management Strategy that we announced in May 2008. Marshaling our collective strengths as a group to further strengthen our overseas and cloud businesses in line with the constantly expanding telecommunications market, we are committed to becoming a "Value Partner" (a partner that delivers new value) and earning the unswerving trust of our stakeholders through continuing to provide safe and reliable services.

Leveraging ICT to address social issues

I believe that it is the mission and corporate social responsibility of the NTT Group to contribute to the resolution of social issues both within Japan and in the world at large through leveraging ICT.

The Great East Japan Earthquake of March 2011 made us more than ever aware of the role of telecommunications as a lifeline in the event of a disaster, and the importance of enabling people to connect with each other in any contingency. Regarding the full restoration of quake-damaged equipment, we will endeavor to building even more reliable networks and further enhance our disaster preparedness throughout Japan by providing new disaster services and improving existing services. We will also accelerate our advanced research efforts and R&D aimed at creating even more disaster-resistant networks and services.

We consider the environment to be of paramount importance, and in 2010, we drew up THE GREEN VISION 2020 as our new vision for addressing global environmental issues. Under this vision, all of our employees are working as one to reduce environmental impacts through initiatives focused on the three themes of creating a low carbon society, implementing closed loop recycling, and conserving biodiversity.

One example is Green NTT, a groupwide initiative that we launched in 2008 to expand our in-house solar power generation as a source of renewable energy that can contribute to the creation of a low carbon society, and we plan to deploy a generation capacity of about 5 MW by the end of fiscal 2013.

I think that by promoting the utilization of ICT, we can also

contribute to the resolution of a wide range of issues facing present-day society, including the declining birthrate and aging population, healthcare and nursing care issues, and the need for better governmental services and education.

For example, where healthcare and nursing care issues stemming from the aging population are concerned, ICT could be used to gather health data from vital sign measurement instruments to enable geographically separated locations to work together on the management of disease treatment and prevention. We currently provide remote health consultation and other similar solutions in cooperation with local authorities and hospitals, and are involved in a number of trials to test remote healthcare solutions that employ the latest technologies.

I feel that we can make a very meaningful contribution to the sustainable development of society by pursuing such initiatives.

Together with our stakeholders

In fiscal 2012, we revised the NTT Group CSR Charter that sets forth our CSR commitment and goals to bring it in line with the ISO 26000 international standard for social responsibility published in November 2010. We have also endeavored to share quantitative indicators in the NTT Group CSR Priority Activities that we set forth in 2008 so as to accelerate the integration of these activities with our business goals. As a result, we have been able to further enhance groupwide CSR initiatives. At the same time, we are treating the repeated transmission problems occurring in our mobile communications and incidents of misconduct by group company employees with utmost seriousness. We have established a task force to work on the groupwide prevention of recurrent transmission problems, and are further enhancing our information and risk management to ensure appropriate business operations.

In addition to the continuation and enhancement of our initiatives in the important areas of human rights and the environment, we will intensify our efforts to fulfill all aspects of our corporate social responsibility and contribute to the sustainable development of society as a global ICT enterprise.

We intend to put even greater priority on dialogue with our stakeholders moving forward, and we hope that you will not hesitate to offer your candid views and suggestions regarding our activities.

Guided by the NTT Group CSR Charter, NTT is committed to promoting CSR activities across the Group that meet the expectations and interests of its stakeholders.

NTT drew up the NTT Group CSR Charter in June 2006 as a basic guideline for the more active implementation of CSR activities by Group companies. It revised the Charter in June 2011.





The NTT Group CSR Charter consists of a statement of our commitment to corporate social responsibility, and the four CSR goals that outline specific priority aspects of our CSR activities.



NTT Group CSR Charter

Our Commitment

As a leader of the information and telecommunications industry, the NTT Group is committed to providing reliable, high-quality services that contribute to the creation of a safe, secure and prosperous society through communications that serve people, communities, and the global environment.

Our CSR Goals	NTT Group CSR Priority Activities
<p>Communication between people and their communities</p>  <p>1. We shall strive to create a richer and more convenient communications environment, and utilize our technology to contribute to the resolution of the various issues faced by societies with aging and declining populations.</p>	<ul style="list-style-type: none"> • Activities that contribute to the further evolution of ubiquitous communications
<p>Communication between people and the global environment</p>  <p>2. We shall strive both to reduce our own environmental impacts and build environment-friendly forms of communications, and to provide information and communications services that help to reduce the impact of society as a whole on the global environment.</p>	<ul style="list-style-type: none"> • Creating a low carbon society • Implementing closed loop recycling • Conserving biodiversity
<p>Safe and secure communication</p>  <p>3. While striving earnestly to ensure information security and resolve telecommunications-related social issues, we shall do our utmost to provide a safe and secure user environment and contribute to the creation and future development of communication culture.</p> <p>4. Fully recognizing the role that telecommunications plays as critical infrastructure supporting society and protecting our livelihoods, we shall strive to offer secure and reliable telecommunications services fortified to withstand disasters and capable of connecting people irrespective of time, location, and other circumstances.</p>	<ul style="list-style-type: none"> • Ensuring information security • Ensuring stable and reliable services as critical infrastructure
<p>Team NTT communication</p>  <p>5. As Team NTT, we pledge to apply the highest ethical standards and awareness of human rights to our business duties, striving to fulfill our mission to society by working for the creation of pleasant workplaces, personal growth, and respect for diversity, and for the further development of a flourishing and vibrant community.</p> <p>• Team NTT comprises all NTT Group employees, including temporary employees, contract employees, employees of our corporate partners, and also former employees who endorse the NTT Group's CSR activities.</p>	<ul style="list-style-type: none"> • Activities that contribute to respect for diversity and equal opportunity • Corporate citizenship activities

CSR management structure

Managing PDCA cycles with group companies according to the NTT Group CSR Priority Activities and Guidelines for NTT Group CSR Activities

NTT created a CSR Committee chaired by a Senior Executive Vice President in June 2005 to ensure the sustained and appropriate implementation of NTT Group CSR activities under two internal committees — the Global Environmental Protection Promotion Committee and Social Contribution Promotion Committee. Group CSR Liaison Meetings are also held periodically to coordinate CSR activities across the whole Group through discussing common issues, sharing information on successful initiatives and other means.

In fiscal 2009, we established our NTT Group CSR Priority Activities and drew up our Guidelines for NTT Group CSR Activities. Based on these guidelines, we work with group companies to monitor progress on the implementation of activities with respect to PDCA cycles and further promote a sense of unity in CSR activities across the Group.

In fiscal 2011, we linked the PDCA management of NTT Group CSR Priority Activities with business planning management so as to enhance the effectiveness of PDCA management. Based on this linkage, in fiscal 2012 we began to set groupwide quantitative indicators, and we will continue to implement groupwide initiatives aimed at integrating our CSR activities with business goals.

NTT Group CSR organization

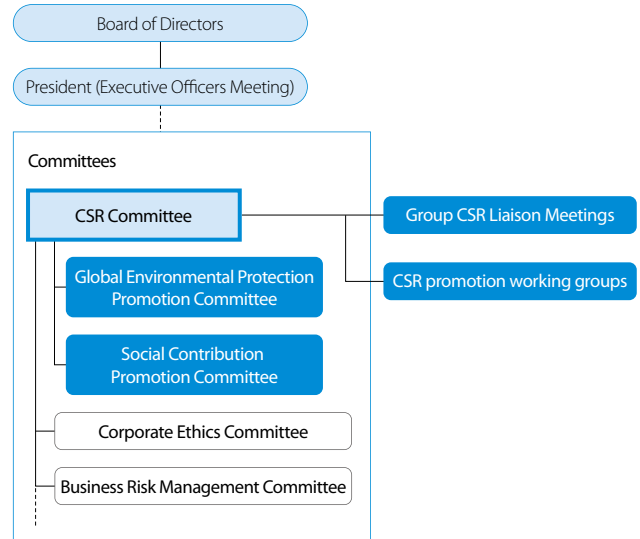

Group CSR Liaison Meeting



Implementing management based on global standards through integrating CSR with business goals

In June 2006, NTT drew up a CSR Charter that laid out its CSR commitment and goals. In fiscal 2009, we drew up eight CSR Priority Activities to provide directionality to group company CSR initiatives in line with the CSR Charter. Group companies have since set yearly CSR activity targets in line with the CSR Priority Activities, and have made steady progress by using PDCA cycle management to achieve those targets. From fiscal 2012, we have started setting quantitative indicators for each of the Priority Activities so as to further promote linkage between CSR activities and business. We have sought to clarify linkage of CSR Priority Activities with business planning indicators by quantifying the status of key initiatives. We aim to complete the setting of quantitative indicators for all eight CSR Priority Activities in fiscal 2013.



Hiroki Watanabe
Senior Executive Vice
President

2006

- Draw up NTT Group CSR Charter

2007

2008

- Formulate NTT Group CSR Priority Activities

Deciding priority activities for each of the four goals set forth in the NTT Group CSR Charter

To drive the implementation of the NTT Group CSR Charter drawn up in June 2006 and take a more unified approach to addressing social issues both within Japan and overseas, we established our NTT Group CSR Priority Activities in November 2008 as activities to be pursued in common by group companies.

In deciding our CSR Priority Activities, we drew up a

list of 49 CSR activities that we saw as important both to the NTT Group and to stakeholders and society at large (see diagram below). We then examined each activity to rate relative importance and PDCA management level to eventually narrow the list down to our eight CSR Priority Activities (see p. 10).

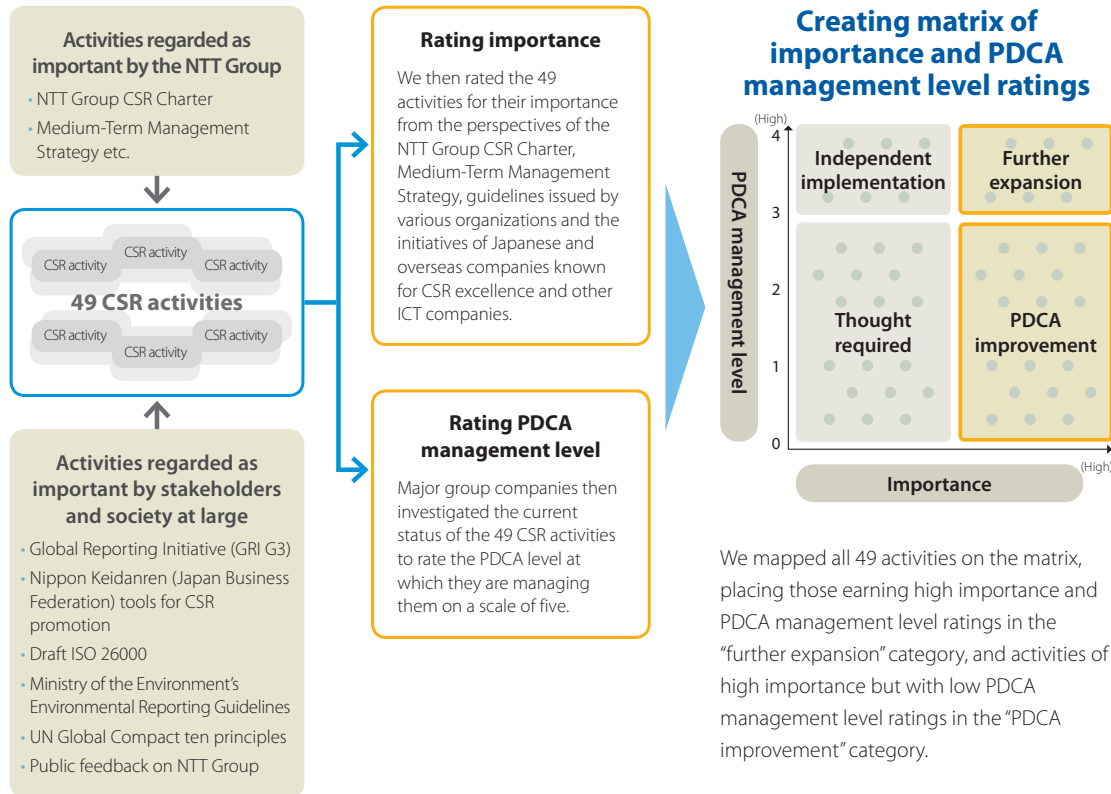

▶ Full differentiation into printed and Web editions

Key CSR reporting improvements >>>

2009

- Formulate of CSR action plans for each CSR Priority Activity

2010

- Start setting common groupwide quantitative indicators for each CSR Priority Activity

2011

Formulation of CSR action plans and setting of quantitative indicators for CSR Priority Activities

In 2009, group companies drew up CSR action plans for each of the eight Priority Activities so as to link them to their respective business plans and take CSR activities across the Group to a higher level. In 2011, we started to

set common groupwide quantitative indicators, and aim to complete the setting of quantitative indicators for all eight CSR Priority Activities in fiscal 2013.

CSR Goals	CSR Priority Activities	CSR action plan ¹ examples (Fiscal 2012)	Quantitative indicators ² (Fiscal 2013)
Communication between people and their communities	• Activities that contribute to the further evolution of ubiquitous communications	Elimination of digital divides by working with communities to provide broadband services, holding of mobile phone usage workshops, promotion of smart community initiatives	Continued implementation of CSR action plans
Communication between people and the global environment	• Creating a low carbon society	Reduction of CO ₂ emissions Results: CO ₂ emissions reduced to 3.791 million tons	Reduction of CO ₂ emissions ³
	• Implementing closed loop recycling	Waste product and paper consumption reduction Results: Final disposal rate for all waste materials reduced to 1.75%, continued achievement of zero emissions for decommissioned telecommunications equipment, total paper consumption reduced to 66,000 tons	Waste product reduction ³ Paper consumption reduction ³
	• Conserving biodiversity	Ecosystem preservation and forest improvement activities Results: 3/11 Recovery Forest Project (tree planting), docomo Woods and other projects	Common qualitative initiatives for ecosystem preservation and forest improvement activities ³
Safe and secure communication	• Ensuring information security	Stronger protection of personal information, provision of information security training	Number of employees receiving information security training
	• Ensuring stable and reliable services as critical infrastructure	Providing high quality, stable communications services, implementing large-scale disaster countermeasures	Continued implementation of CSR action plans
Team NTT communication	• Activities that contribute to respect for diversity and equal opportunity	Promoting disability employment, supporting women's career development, nurturing a global workforce	Ratio (number) of women in managerial positions
	• Corporate citizenship activities	Operation Clean Environment (local community cleanup) participants Results: Approx. 118,000 participants PET bottle caps collected (Ecocap Movement) Results: Approx. 31.9 million caps	Number of Operation Clean Environment (local community cleanup) participants, number of PET bottle caps collected (Ecocap Movement)

1. Prepared by group companies for each CSR Priority Activity in line with the nature of their respective businesses

2. Setting of common groupwide quantitative indicators

3. Initiatives leading up to fiscal 2021

▶ Announcement of NTT Group CSR Priority Activities

▶ Publication of booklet for China

▶ Launch of Stakeholder Dialogue

▶ Stakeholder dialogues for separate CSR Priority Activities

Providing a diversity of services throughout the world as a global ICT group

Spurred by the growth of broadband in both fixed line and mobile communications and the rapid spread of smartphones, ICT markets around the world continue to undergo major changes as an increasing diversity of sophisticated services and devices are rolled out. The NTT Group is driving the evolution of ICT markets by making maximum use of its cutting-edge R&D and global management resources to provide ICT solutions that seamlessly support the creation of diverse services and the business growth of global enterprises. We are committed to promoting the utilization of ICT to create a safe, secure and prosperous society by addressing the management issues of our stakeholders worldwide, and helping to resolve issues faced by societies today throughout the world in many different areas including healthcare, nursing care, education, environment, energy, security and disaster preparedness.

Provision of
ICT solutions to
60
over
countries and
territories

High quality data
centers in
31
cities

International
roaming covering
219
countries and
territories

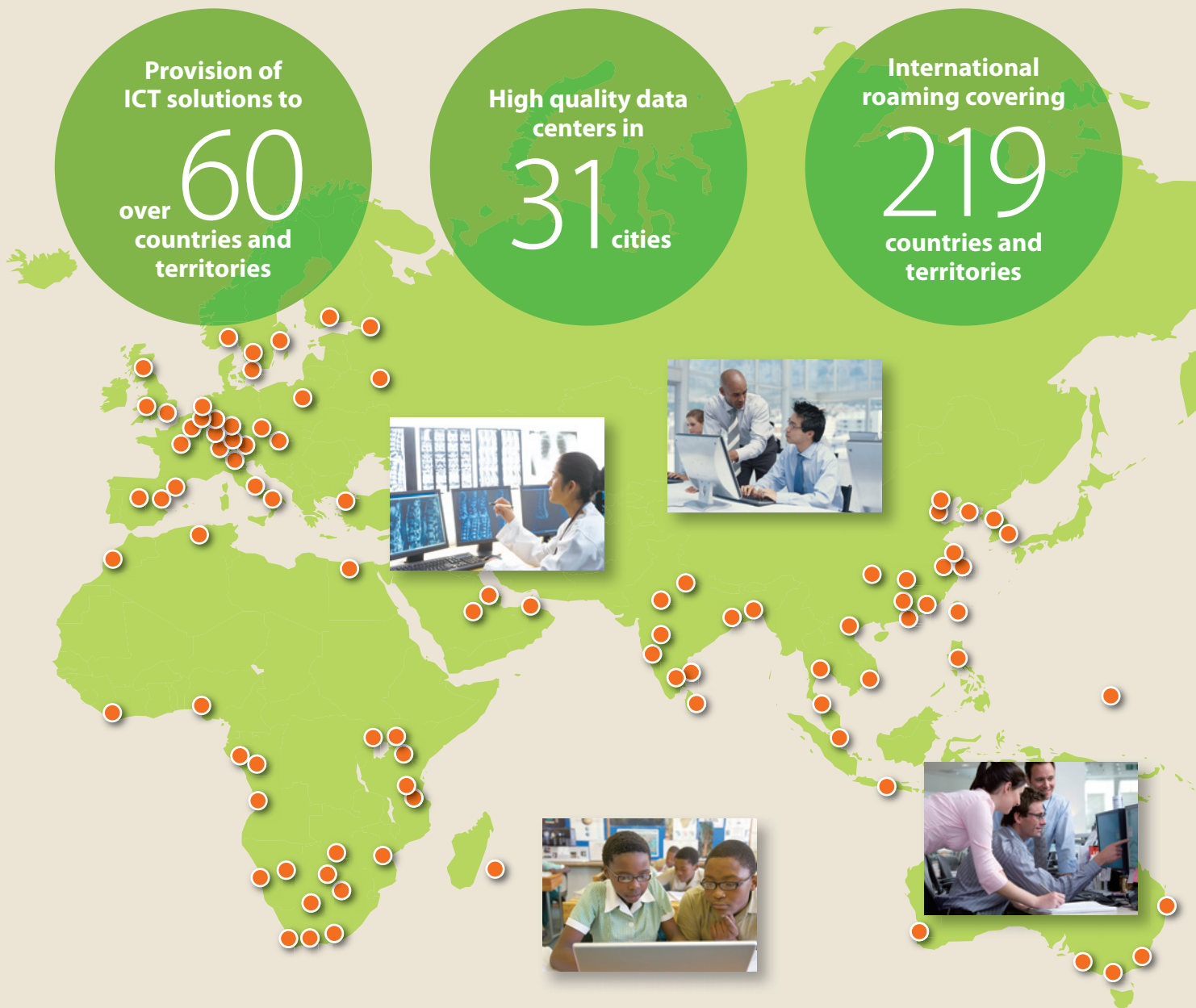

● : Key overseas sites (as of January 31, 2012) Figures as of March 2012

An overseas group company view



As a leading information and communications technology company, Dimension Data strives to make a difference - to our clients, our people, our partners and our community - in a responsible and sustainable way, whilst always putting our clients at the center of everything we do. Our Corporate Social Responsibility (CSR) program enables our people to support local communities and the environment in a meaningful way, with a focus on education – specifically the use of technology in education – and environmental sustainability. The program fosters a high level of employee engagement, facilitating employees’ relationships with one another, with the business and most importantly, with our local communities. To enhance the impact of their respective CSR activities going forward, Dimension Data and the NTT Group intend to share best practices and implement joint initiatives to address the social and environmental needs of the communities in which we operate.

Marilyn Rose Chaplin
Group Executive Human Resources, Dimension Data

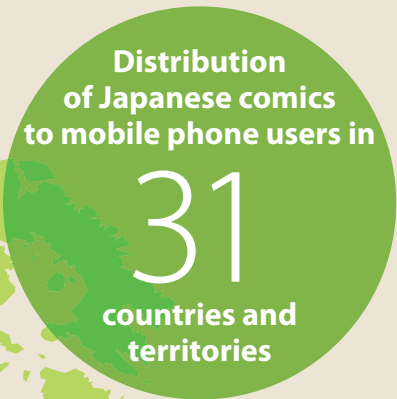

***Tier 1 provider:** A provider with a global broadband IP backbone under its sole control that can reach every other network on the Internet without purchasing IP transit or paying settlements. There are only a handful of tier 1 providers worldwide.

An overseas group company view



With NTT DATA's expanding global presence, we are leveraging our scale, innovative offerings, and talented professionals to serve more clients in more markets. With this growth, we have an increasing opportunity and responsibility to improve the communities we serve. Success can no longer be measured solely in traditional business terms but should include contributions towards long-term growth and sustainability. Collaborating across the NTT Group, we have the ability to make a greater impact on society with thoughtful, innovative, and often times, simple, actions and solutions.

John McCain
President and CEO, NTT DATA, Inc.
Senior Vice President, NTT DATA Corporation

An initiative in
Southeast Asia

Southeast Asia



Development of flight procedure design system to help create safer airline infrastructure

Improving the reliability of air traffic control is an urgent aspect of creating a safer aviation infrastructure for Southeast Asia's rapidly growing airline industry.

NTT DATA has been involved in air traffic control systems since the 1970s, and leveraged this rich experience to develop PANADES as a flight procedure design system that conforms with International Civil Aviation Organization (ICAO) standards. PANADES not only improves air safety, but also helps to reduce fuel consumption and CO₂ emissions by automatically processing complex computations rapidly to create the best possible flight procedure according to aircraft performance, topography, weather, air traffic congestion level and other factors. After initial deployment in Thailand in July 2011, PANADES has been supplied also to Indonesia and Vietnam through the Japan International Cooperation Agency (JICA), and is now supporting air safety over an increasing area of Southeast Asia.





An initiative in **Europe**

Improving Internet environments by establishing new access nodes in three East European countries

Internet traffic in Eastern Europe grew by 100% or more every year from 2006 to 2010, and continues to grow rapidly, but the deployment of broadband infrastructure has failed to keep up with this growth, and a great many Eastern European Internet users have to cope with chronically slow connection speeds as a result. Leveraging long-standing ties of cooperation in the region to address this situation, NTT Communications' European subsidiary NTT Europe worked with telecommunications carriers in Eastern Europe to establish three new access nodes in Budapest (Hungary), Bucharest (Romania) and Sofia (Bulgaria) in November 2011. By linking directly to NTT Communications' global backbone and the access it provides to content and ISPs of countries throughout the world, the new access nodes provide many more people in Eastern Europe with much speedier and less stressful Internet connections.

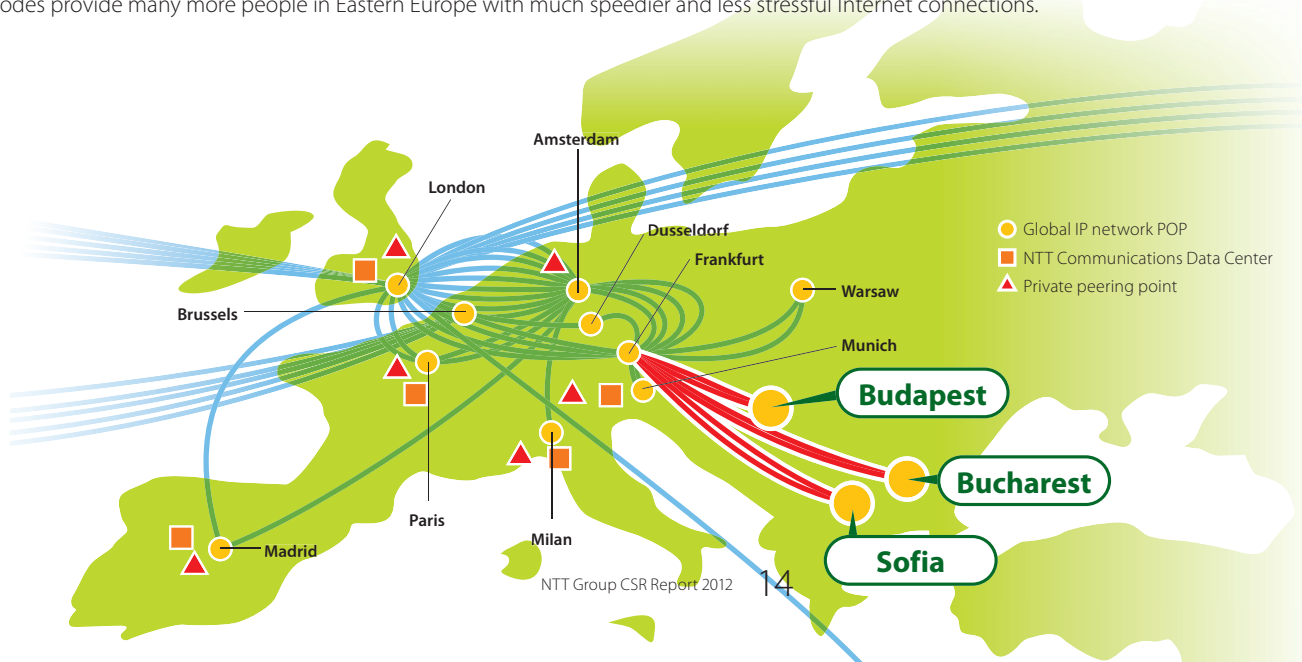



 Africa

An initiative in **Africa**

Nurturing potential scholastic abilities through the provision of an e-learning program

Since 2006, Dimension Data has been providing an educational program which employs an e-learning system to raise the level of education in underserved local communities in South Africa and nurture the potential scholastic abilities of school students.

This program, which includes multiple curricula with the full backing of South Africa's Department of Basic Education, utilizes screens and "e-learning carts" carrying computers to present classes. The entire curriculum is hosted on the e-learning trolley machine and can be easily updated to provide the latest educational content. Lessons are accessed via a computer in the trolley, and projected onto the drop-down screen. The carts are also equipped with DVD players to provide audio-visual education. Quality, practical educational materials such as these enable teachers to devote more individual attention to students.

In addition to providing participating schools with the e-learning carts and other necessary equipment, Dimension Data has also instructed over 4,000 teachers in the use of the system to promote its utilization by as many schools as possible.

The e-learning system has been deployed in over 60 schools in all of South Africa's nine provinces, with over 30,000 students participating in the program. Dimension Data is aiming to boost this number to 40,000 by 2015.



E-learning cart

An initiative in **Japan**



Pilot project to jointly test remote healthcare solutions

The NTT Group has enlisted the cooperation of patients being cared for at home, users of home nursing care services, pharmacies and other parties to launch a pilot project with Kameda General Hospital, one of Japan's leading medical facilities, and home nursing care service provider Kameda Industrial Co., Ltd. to test remote healthcare solutions for supporting home-based healthcare in and around the city of Kamogawa in Chiba Prefecture.

The project, which makes use of NTT East's broadband network services and NTT DOCOMO Android tablets and mobile services, is designed to address the four objectives detailed below. NTT Corporation is managing the whole project and handling system development, evaluation and testing.

NTT is planning to carry out further home-based healthcare pilot projects aimed at leveraging broadband networks and ICT to build total care value chains that enhance community-based healthcare.

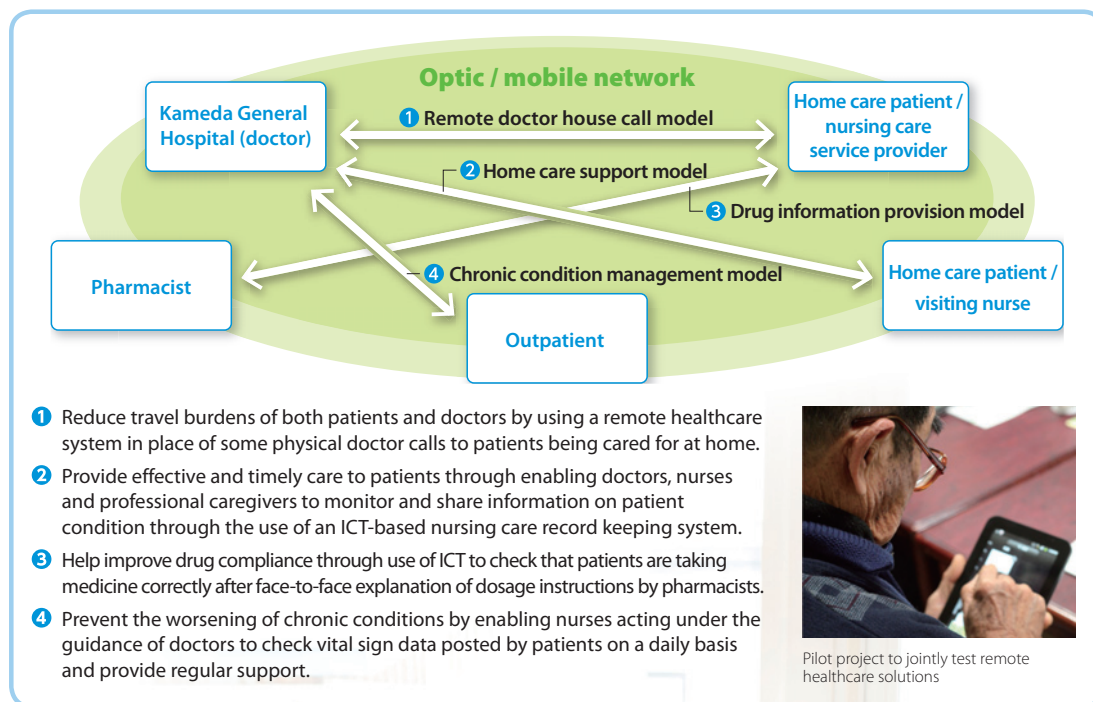

Pilot project to jointly test remote healthcare solutions





Shanghai



Beijing



Tokyo

Dialogue (videoconference)

Maintaining and enhancing initiatives in China to contribute to the development of society and resolution of social issues

People throughout the world are now looking to China as a key driver of the global economy. China has grown by leaps and bounds in recent years, but at the same time faces a wide range of social issues, including environmental problems and growing income disparities.

The NTT Group has long been doing business in China and has put down firm roots there. For this feature, we used a videoconferencing system to connect our sites in Beijing, Shanghai and Tokyo, and got key people in major NTT Group companies to talk about how the Group could leverage its core competences and business assets to help address the issues faced by Chinese society.

Key remarks by the participants are presented below.

Beijing

Tokyo

Shanghai

Contributing to the development of Chinese society through providing ICT services and technical support for building communications infrastructure

China's industry and economy has grown tremendously over the past few years. What kind of role has the NTT Group played in this development?

Inaba (NTT): China's recent rapid economic and industrial growth wouldn't have been possible without the development of its ICT infrastructure and the spread of the Internet and mobile phone networks. The NTT Group has been doing business in China for about 30 years, and I feel that we've played a major role in the development of the country's ICT environment. How do the rest of you feel from the perspective of your respective group companies?

Zhang Jianming (NTT Communications China): NTT Communications China has helped develop China's business environment and improve its investment environment through providing system integration solutions and Internet related ICT services for Chinese as well as Japanese and other foreign-owned companies.

We also work with other NTT Group companies such as NTT FACILITIES CHINA and DOCOMO China to provide local Chinese companies with technical assistance. For example, we've provided consulting services to local telecommunications carriers for various products including the construction of FTTH networks and data centers. I think that endeavors like these have helped raise the level of ICT services across China as a whole.

Kanda (NTT DATA): NTT DATA has also helped to build China's ICT infrastructure, for example by building and operating the backbone systems for the People's Bank of China and forerunner of the Postal Savings Bank of China in the 1990s. More recently, we've been focusing on doing business with Chinese companies, as well as handling Japanese offshore business and ICT outsourcing business for Japanese companies operating in China.

Oishi (NTT Advanced Technology): We've been providing Chinese optical communications equipment makers with optic fiber materials through local agents for over ten years now. I think we've been able to contribute indirectly through these activities to the development of China's communications equipment industry and to bridging digital divides in China.

Nakagawa (CPTL): Our role is to support financial aspects of the activities that you've all been talking about up to now. Our parent company, NTT FINANCE, gets a very high rating from credit rating companies, and we help China to develop by leveraging that creditworthiness to procure funds at low costs to finance communications and postal service projects in China.

Helping to create a low carbon society through promoting energy efficiency and participating in smart community experiments

China's economy continues to grow briskly, but the country also faces issues such as traffic congestion, environmental problems and growing income disparities. How do you think the NTT Group can help to address these issues?

Inaba: Our Energy and Environment Systems Laboratories (NTT EESL) is conducting research in technologies that leverage ICT to reduce environmental impacts. NTT EESL has cooperated in monitoring Beijing's atmospheric pollution, and when the Beijing Olympics took place in 2008, we fitted a stadium with a lighting system that makes use of solar power. We've been actively helping China to reduce environmental impacts through these and various other activities. We've also been working with group companies on the development of "smart communities" as the building blocks of the low carbon society of the future, and we plan to do similar things in China.

Honma (DOCOMO China): As an initiative connected to the smart communities of the future, DOCOMO China is participating in a closed loop social infrastructure construction pilot project being implemented by the Japanese government's New Energy and Industrial Technology Development Organization (NEDO) in the city of Gongqingcheng in Jiangxi Province.

The project aims to reduce environmental impacts through deploying electric buses that don't emit CO₂. We'll be helping with the building of a bus operation information system that informs the public of bus location, waiting time and other information through smartphones and digital signage.

Kanda: NTT DATA (China) is also participating in a NEDO-backed pilot project in Beijing to test a new traffic system. The experiment involves fitting 12,000 cars in Beijing with sensors to gather data on geographical position, speed, accelerator and brake use and such like. The data will be analyzed to explore ways of preventing traffic jams and promoting eco-driving.

Yamada (NTT FACILITIES CHINA): Data center construction is booming in China at the moment, but data centers are very energy hungry, and so making them more energy-efficient is an urgent issue. At NTT FACILITIES CHINA, we're accordingly leveraging the abundance of technology and expertise that we've built up in Japan in, say, efficient air conditioning control systems and such like to provide design and technical consulting services for building energy-efficient data centers. Going forward, we're also planning to work with NTT EESL to deploy efficient high voltage direct current (HVDC) power supply systems.

Beijing



Masato Inaba

Chief Representative in China
NTT

Beijing



Takuya Nakagawa

President & CEO
Cosmos Posts and
Telecommunications
International Leasing

Beijing



Nelly Zhang

Country Sr. Hr Manager
Dimension Data

Protecting lives by monitoring the safety of bridges and enabling food traceability

As China has become increasingly consumer-oriented, its people are showing more concern over safety in society. What are your views on the role of the NTT Group in this area?

Kanda: A great many incidents of bridges suddenly collapsing as a result of aging have occurred in the past ten years in China, making it a serious social issue here. At NTT DATA China, we're participating in a project to equip bridges with sensors to monitor aging and risk of collapse so as to prevent such disasters from happening. We're conducting field trials that make use of the latest data analysis technologies to analyze the huge amounts of data that get sent to us, and we're now preparing to operate a bridge monitoring system in Jilin Province.

Honma: I think that we can leverage DOCOMO China's core competence of mobile technology to contribute to the creation of a safe and secure society in China in two key areas over the long term. One of those is traceability systems to ensure the safety of foods and pharmaceuticals. The second is welfare-related applications. China is destined to follow in Japan's footsteps to become an increasingly aging society with more and more old people living on their own. As such, I can see great potential demand for remote monitoring services that use sensors and mobile communications to keep an eye on the well-being of elderly people.

Oishi: We participated in a project in Chile to build a communications system for linking people at the working faces of mines with mine management offices. I'd like to apply the knowledge we gained there to China too, to help enhance the safety of operations in coal mines and other mining industries here.

Collecting donations and supporting charities to help address poverty and recovery from disasters

What are you doing to tackle issues such as income disparity and large-scale disasters?

Inaba: These are not problems that the NTT Group can resolve on its own, but we're all living here in China, and I think it's important for us to do our utmost to help out as a corporate citizen.

Nelly Zhang (Dimension Data): At Dimension Data China, we're actively supporting projects of charities that address poverty in the Asia Pacific region. Within China too, we're working with China Charity Federation to provide equipment and learning materials to junior high schools, and we're also paying the school fees of 25 junior high school students from households facing poverty in Hebei Province for three years from 2012. Another thing we're doing is supporting schools for the children of migrant workers from the countryside in large cities through donations and visits by employees.

Kanda: NTT DATA (China) employees also have a keen awareness of the importance of contributing to society, and they start collecting money to help disaster victims almost as soon as they hear news about a disaster. They did so after last year's Great East Japan Earthquake, and again this year when Beijing was hit by torrential downpours and flooding in July. We're really proud of this kind of corporate culture.

Zhang Jianming: NTT Communications China employees have also long collected donations voluntarily for such causes. The company too has itself started to make contributions recently, donating about 300,000 yuan since last year to disaster zones and charity organizations.



Localizing personnel and management to put down firm roots in Chinese society

China has the world's largest population. In this sense too, couldn't the NTT Group be seen as contributing to Chinese society through its many different activities by hiring and training local people and such like?

Inaba: Yes, indeed. The NTT Group currently has over 70 sites in 23 cities in China, and employs close to 10,000 people in China.

Kanda: NTT DATA (China) employs about 4,000 people if you count our 13 key group companies.

Inaba: Most of these people are local Chinese, but we also have people from Singapore, Malaysia, Australia, the USA and other

Shanghai



Zhang Jianming
President & CEO
NTT Communications China

Shanghai



Masayuki Honma
President & CEO
DOCOMO China

Shanghai



Shoichi Yamada
President & CEO
NTT FACILITIES CHINA

Tokyo



Fumio Kanda
Senior Vice President, NTT DATA
Deputy Chair & CEO, NTT DATA
(China)

Tokyo



Mamoru Oishi
Chief Representative, Shanghai
Rep. Office
NTT Advanced Technology

countries as well as, of course, Japan. We have a very cosmopolitan workforce, and we seek to drive our creativity through leveraging this diversity.

Zhang Jianming: It's also important to localize management too by appointing locally hired employees to positions of responsibility according to their abilities and suitability. NTT Communications China used to be managed largely by people posted here from Japan, but in recent years, we've been sending gifted Chinese employees to Japan to work in the NTT Group there, and appointing these people to managerial positions here once they've gained experience in Japan has become the norm. Currently, over 70% of our managers and above, including myself, are local hires, and I think that this kind of training and hiring of local people definitely contributes to society.

Leveraging group synergy to take on valuable new challenges

What do you think the NTT Group needs to do to contribute even further to Chinese society moving forward?

Oishi: It's of course important for individual group companies to involve themselves in business that is valuable to society, but I think it's also important for the NTT Group to make maximum use of the synergy that can be generated between group companies to come up with valuable solutions that other business groups are unable to provide.

Yamada: Group companies have always worked together on various projects, but I'd agree that we need to talk even more often with each other and actively create possibilities for new kinds of cooperation. For example, we handle things like car park management systems as part of our building management solutions business, and I'm sure that if we made effective use of the technologies of group companies, we could probably create even more convenient and energy-efficient systems.

Honma: Smart communities designed for maximum energy



efficiency and comfort are, I think, another good example of a field in which the NTT Group could make the most of its collective strengths. By achieving success with such cutting-edge projects, the NTT Group should be able to boost its stature and worth in Chinese society.

Nakagawa: CPTL has won the trust of China's postal services, telecommunications and financial services industries and built up an extensive network of connections through its business. I think we could put this trust and these connections to use by serving as a bridge



between group companies and China's business and industry to contribute as the NTT Group to projects of great value to society, such as providing China with more advanced financial systems or more efficient logistics.

Nelly Zhang: To generate more synergy, I think that we should think along the lines of launching experimental projects under NTT Corporation's leadership, using them to develop better, more collaborative processes between group companies. As a human resources manager, I'd very much welcome the opportunity to participate in events aimed at bringing people from different group companies together, or groupwide citizenship activities.

Inaba: I too want to raise the level of information sharing and networking between all of us in the NTT Group working here in China, much as you've all suggested. We aim to work with you to drive collaboration within the Group in China, share the fruits of our R&D with China, build new business models for Asia, and through these endeavors, make a bigger contribution to the sustained development of Chinese society.

NTT focuses on innovation that addresses energy, environmental and other issues faced by today's society.

The NTT Group is involved in a wide range of ICT-related R&D that contributes to the resolution of environmental, governmental, educational, healthcare and other social issues. Specific fields include innovative cloud-based communications services, platform technologies for next-generation information networks, world-class photonic technologies and other cutting-edge basic research aimed at uncovering new principles and developing new products.

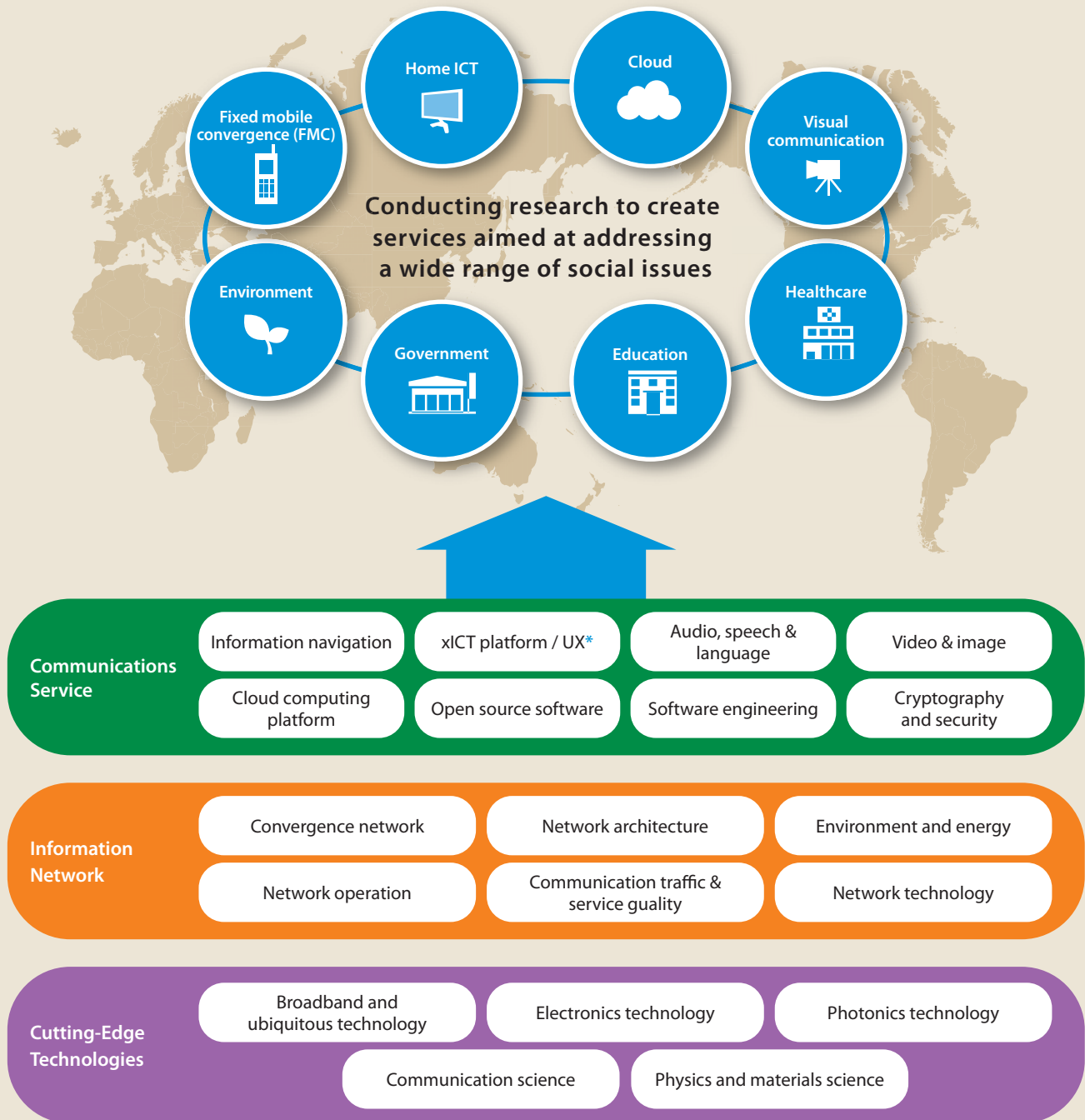

*UX: User experiences

Energy network initiatives for supporting safe, secure and energy-efficient smart communities

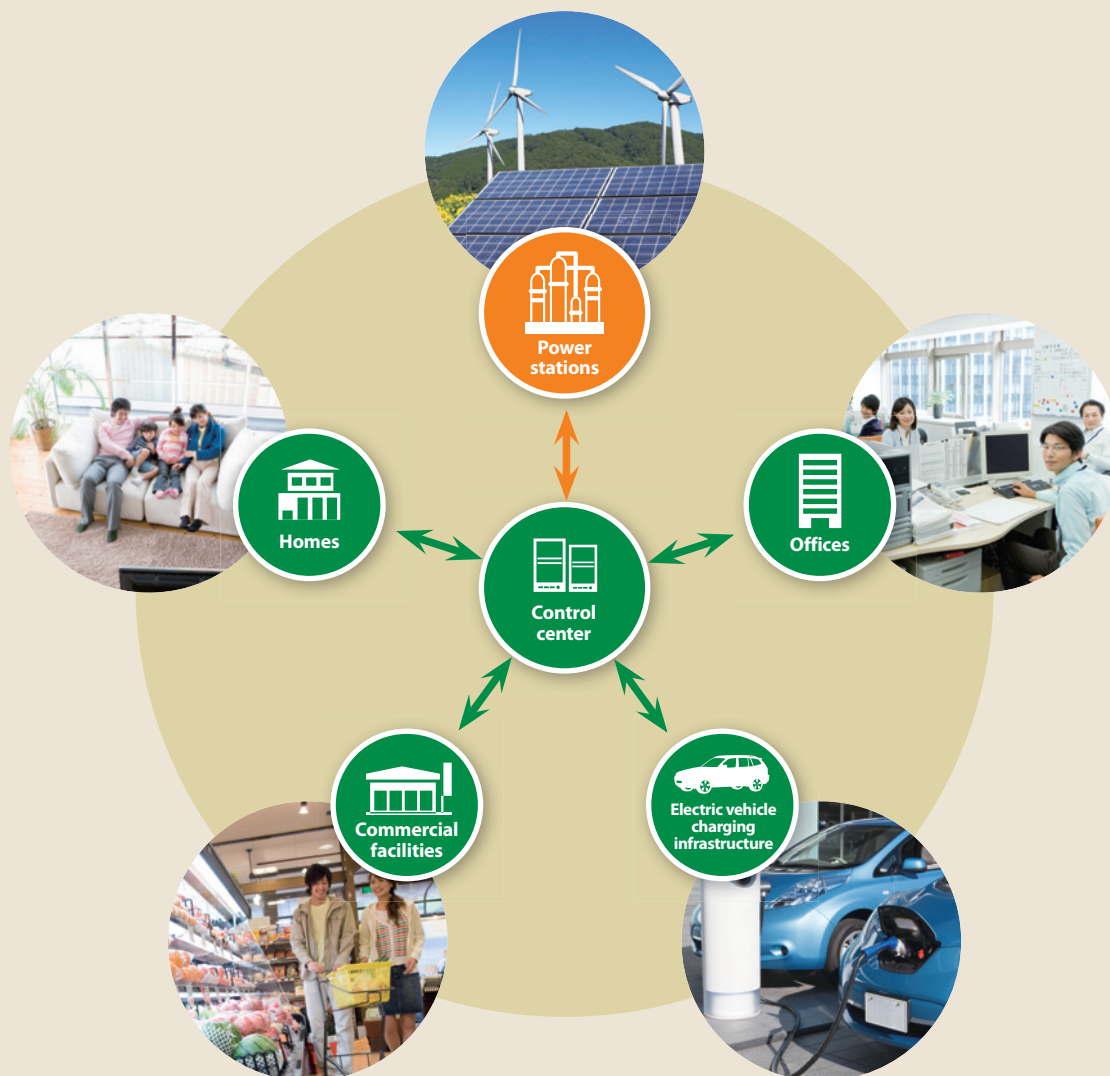

As concern over global warming and climate change grows, reducing greenhouse gas emissions has come to be treated as an urgent priority by international society. In Japan, moreover, electricity shortages during summer and winter peak consumption periods have become a serious issue in the wake of the Great East Japan Earthquake, spurring nationwide efforts to save electricity and energy. This situation has also sparked growing interest in the concept of the “smart community” as a model for next-generation social infrastructure.

Smart communities make use of “smart grids” that employ ICT to supply electricity more efficiently, and HEMS / BEMS* and other next-generation energy management systems that leverage ICT to optimize electricity consumption in homes, office blocks and other buildings. The integrated management of such systems would not only enable the optimization of electricity supply and demand to ensure a stable supply of power at the local

community or city level, but would also reduce environmental impacts through driving the deployment of energy-efficient devices and renewable energy generation. The future looks promising also for new services that use energy supply and demand visualization to bring peace of mind and enrich our everyday lives.

We were among the first to realize the importance and potential of smart communities, and our research laboratories and group companies have regularly joined forces to actively participate in joint research and pilot projects with both the government and private sector and pursue other initiatives aimed at making smart communities a reality. In the following pages, we introduce a range of specific examples of R&D aimed at developing the ICT required for next-generation energy networks.

*HEMS: Home Energy Management System
BEMS: Building Energy Management System

Example 1

Imagining the ideal smart community

Pooling collective group strengths to develop an overall picture of the smart community

Next-generation infrastructure for enabling intelligent and efficient electricity consumption

With the spread of renewable energy generation, energy networks have begun to shift from the one-way supply of electricity from power utilities to consumers to become two-way systems, with consumers themselves generating electricity and feeding it into the power grid. With these changes prompting a lively debate at the national level on future energy supply and demand, the NTT Group is developing an overall picture of community-level energy supply and demand optimization services required to create smart communities, and has launched preparations for testing proposed technologies.

Leveraging demand response to save electricity

Community-level energy supply and demand optimization services are aimed not only at enabling the local utilization of energy generated by consumers, but also at leveraging ICT to encourage consumers to save electricity. The latter depends on the deployment of "demand response" mechanisms for alerting consumers when electricity is in short supply or the grid is suffering instability, and for actually turning off noncritical devices at times of severe shortage.

Planning tests for large numbers of users

NTT's Network Technology Laboratories is currently spearheading preparations for experiments to test the feasibility of demand response and other aspects of smart community services.

Phase 1 experiments launched in October 2012 are employing a test room equipped with smart meters¹, a solar power system and high efficiency batteries in addition to various consumer appliances. We plan to build management servers for regulating home electricity supply and demand and data aggregation servers for processing data from electricity consumers² and suppliers, and conduct experiments to test the functionality and energy-saving potential of the system³.

The NTT Group possesses technologies and expertise in data center energy conservation, DC power supply, complex data analysis and many other areas that can be applied to the development of smart communities. We aim to marshal these collective strengths to develop next-generation energy networks that deliver unprecedented efficiency and convenience.

1. High functionality electricity meters equipped with communications, monitoring, management and other functions
2. Capable of processing data from up to several thousand electricity consumers
3. System that combines America's OpenADR demand response standard with the ECHONET Lite standard for remote monitoring and control of consumer appliances



Hidetoshi Tatemichi

Senior Researcher
Network Technology Project
Network Technology
Laboratories

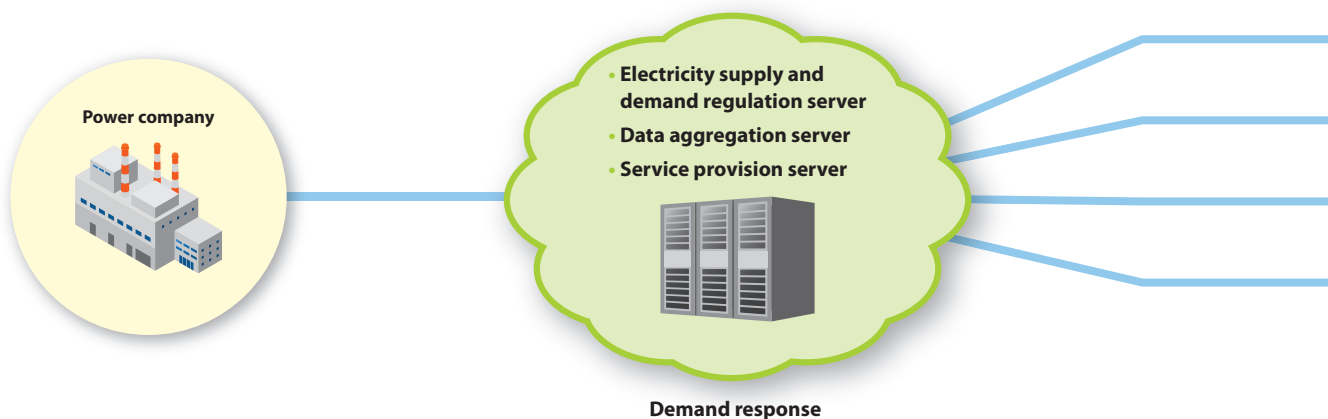

Example **2**

Driving the spread of smart communities

Standardizing network integration control systems that constitute the community "nervous system"

Ensuring device compatibility vital to system uptake

Homes, offices and other buildings that consume electricity in smart communities will be equipped with communications and control devices known as gateways that link up air conditioners, lighting, solar systems and other equipment through wired and wireless connections. These gateways will exchange electricity supply and demand information with the supply-side platform to optimize electricity consumption by turning off noncritical equipment and other means as occasion demands.

Leading electronics manufacturers and home builders in Japan and other countries have in recent years been energetically testing systems aimed at creating smart electricity consumption models like this, but their use of proprietary technologies and communications protocols has resulted in a lack of compatibility between devices.

Working on standardization with major electronics manufacturers

To remedy this situation, the Ministry of Internal Affairs and Communications launched a Project to Standardize and Promote Network Integration Control Systems in 2010. The NTT Group and four major Japanese electronics companies were selected to participate in this project*.

When drawing up the standard, we put priority on flexibility and scalability so as to enable its use by many different businesses for a diversity of services, and on the protection of user privacy so as to enable people to use these systems with confidence. We also focused on making the network system itself energy-efficient, and in tests carried out at the NTT Musashino R&D Center, we surpassed our target of 10% to achieve an electricity consumption reduction of 14%.

Since completion of the project, we and over 20 other enterprises have participated in a standardization committee to examine and draw up proposals aimed at creating an international standard. We will continue to participate actively in this process and contribute to the implementation and spread of smart communities.

* The NTT Group worked on a standardized home DC interface and remote monitoring protocol for controlling network bandwidth and equipment, as well as handling environmental assessment technology for all interfaces.



Jun Kato

Energy Optimization Technology Group
Senior Researcher
Energy Systems Project
Energy and Environment Systems
Laboratories

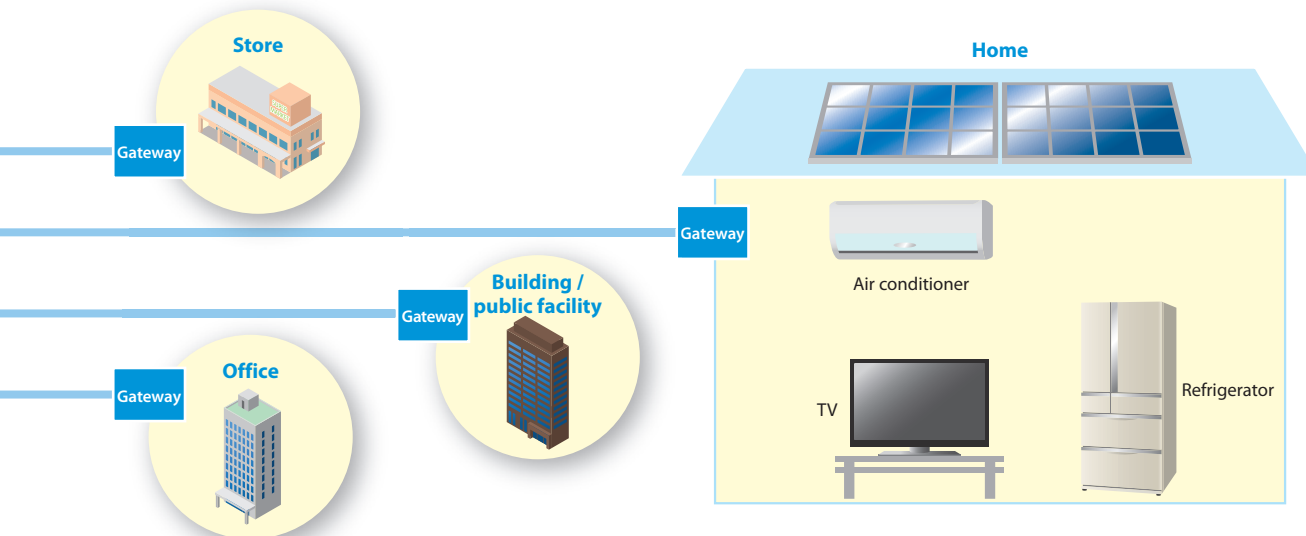

Example **3**

Rethinking power supply systems

Driving the uptake of DC power supply systems that offer greater reliability and energy efficiency

Reducing AC to DC conversion losses through use of DC supply in the home

Commercial power is supplied in the form of alternating current (AC) to supply electricity, but the internal circuits of TVs, PCs, phones and many other consumer appliances run on direct current (DC). For this reason, AC is converted to DC before being used, and a certain amount of energy is used up in the conversion process.

In recent years, however, home DC power supply that feeds DC to ordinary households is drawing attention as a means of reducing such unnecessary power losses. Home DC power supply is not only energy efficient, but would also conserve resources since it eliminates the need for AC adapters using so many different standards.

Creating efficient power supply systems by reducing current conversion power losses

Home DC power supply is enabled by using a power conditioner to convert AC into DC of about 300-400 V, and then converting this into high-voltage DC power of 300 V or more for medium to high wattage appliances such as air conditioners and refrigerators, and low-voltage DC power of 12-48 V for low wattage devices such as ICT equipment and smaller household appliances. Use of a power conditioner to carry out one-stop AC-DC conversion results in a far smaller power loss than the present system in which each appliance converts AC to DC separately. Smart communities in particular enable the creation of highly reliable and efficient energy networks because key components such as

solar systems, fuel cells, electric vehicles and battery units can all be connected easily as equipment operating on DC.

Accumulating world-class technology and expertise through building and operating communications facilities

The simplicity, reliability and energy efficiency of DC power supply systems prompted us to use them as the main form of power supply for NTT Group telecommunications equipment, and we have as a result accumulated world-class technology and expertise in DC power supply. In recent years, we have also equipped our data centers with DC power supply to share the benefits of this technology with society at large. We also established the Green Grid Platform at Home (GGP@H) Alliance* in 2009 to promote the deployment of DC power supply systems in office buildings and homes, and we are currently working on the standardization of protocols and development of technology for effectively achieving CO₂ emissions reductions of over 10%.

*An alliance of universities and private companies that have come together to establish home DC power supply systems as homegrown Japanese technology for worldwide adoption (Secretariat: Energy and Environment Systems Laboratories)



Norimitsu Tanaka

Senior Researcher
Energy Supply Technology Group
Energy Systems Project
Energy and Environment Systems
Laboratories

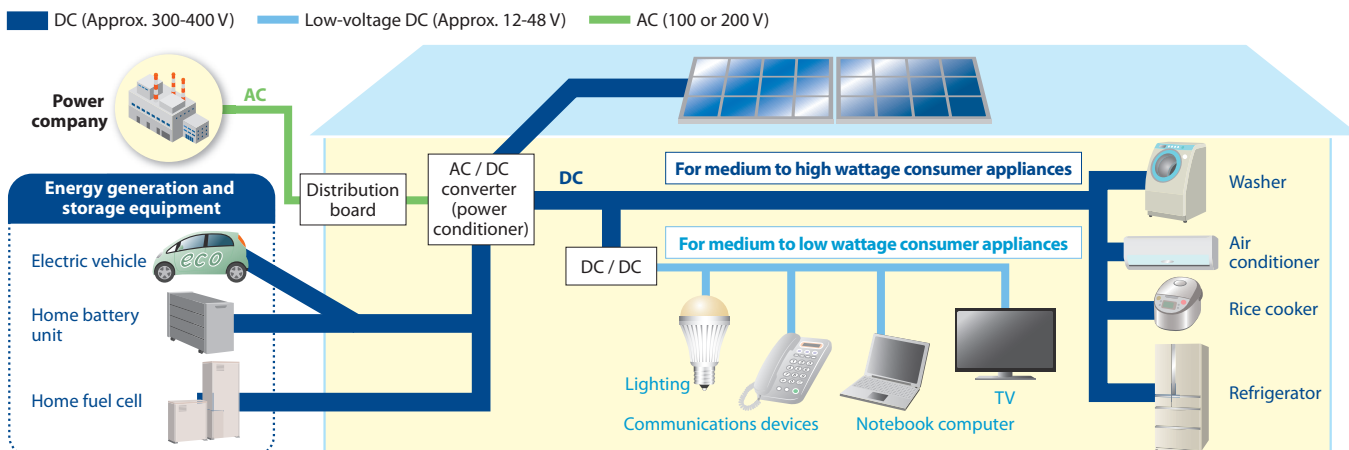

Example **4**

Enabling the smart utilization of electricity consumption data

Contributing to the creation of safe and secure local communities with remote monitoring services that utilize electricity consumption data

Leveraging ICT to remotely monitor the well-being of elderly people living on their own

With Japan's low birthrate and increasingly aging population, the social isolation of elderly people living on their own has become a serious problem. To address this situation, the NTT Group is working on the implementation of remote monitoring services that leverage ICT to check on the presence of activity within a household by monitoring electricity consumption data.

Utilizing original analytical technology to identify human-instigated electricity consumption

In addition to background electricity consumption by refrigerators, ICT devices, household appliances in standby mode and so forth, household electricity consumption data includes consumption stemming from conscious human activity such as using an electric kettle or a hair dryer. We have developed an algorithm for analyzing the frequency distribution of electricity consumption to identify and separate such human-instigated electricity consumption from the background electricity consumption of household appliances. Using this algorithm, we calculated reference values for precisely identifying conscious human utilization of appliances according to the electricity consumption patterns of residents. Monitoring daily electricity consumption based on these reference values would enable us to detect if, for example, no conscious human utilization of appliances had occurred for some time, alerting us to the possibility that the resident concerned might be in need of assistance.

Trial achieves detection precision of over 90%

We conducted a trial of this remote monitoring service from January to March, 2011, using our reference values to monitor electricity consumption data of condominium apartments occupied by single elderly people. The trial showed that we were able to detect human activity from electricity consumption data with precision of over 90%.

Unlike existing monitoring services that use cameras or human presence sensors, this electricity consumption data-based monitoring service does not give people the unpleasant feeling of being watched, and also detects activity in any room. Another advantage of this kind of service is that it will be very easy to deploy when smart meters equipped with communications functions become commonplace in the near future.

With the aim of eventually offering the service, we are planning to further boost detection precision by conducting trials in different seasons when electricity consumption patterns also differ.



Hiroshi Inoue
 Researcher
 First Promotion Project
 Energy and Environment
 Systems Laboratories

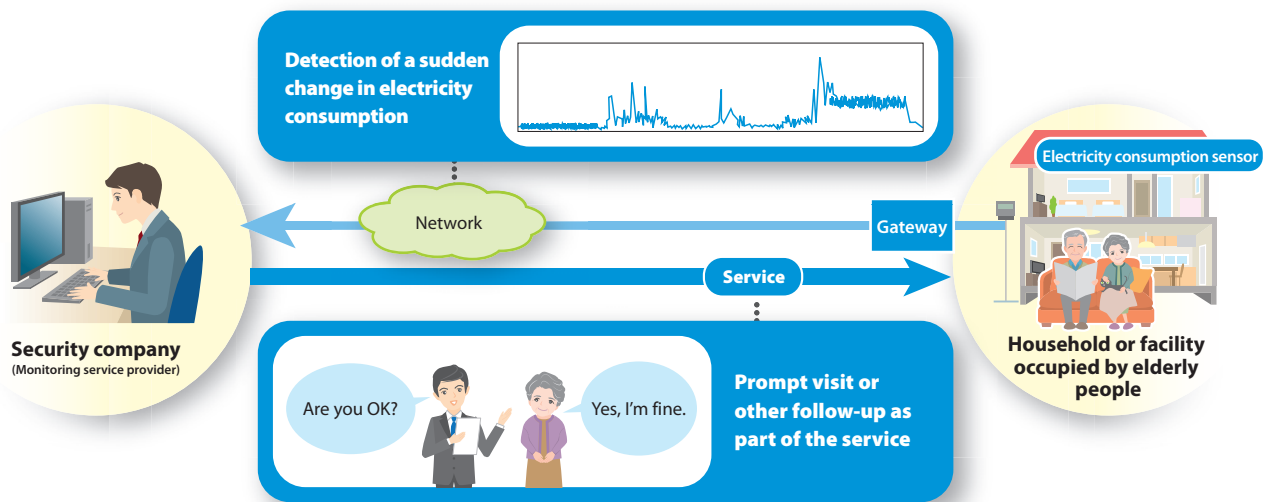

Dialogue

Engaging in sincere dialogue with society and creating valuable products and services that address pressing social issues

Japan currently faces a wide range of serious issues that are the subject of national debate, including energy and environmental problems and the rising cost of social security. Hiromichi Shinohara, Executive Vice President and Director of the NTT Group's Research and Development Planning Department, talks here with journalist Eiko Oya about how NTT can leverage its advanced ICT technology to help to resolve these issues.



Hiromichi Shinohara

Director of Research and Development Planning Department,
Executive Vice President, NTT

Eiko Oya

Journalist, Director of Oya Soichi Library

Our dependence on electricity revealed by the Great East Japan Earthquake

Shinohara: The NTT Group's telecommunications equipment suffered immense damage as a result of the Great East Japan Earthquake. The quake caused a great deal of direct damage such as severed lines and shattered mobile base stations, but the largest cause of the transmission failures we suffered was the prolonged power outages.

Oya: But doesn't the NTT Group have backup power sources to keep its telecommunications equipment running?

Shinohara: Yes, but we hadn't anticipated such prolonged outages, and as backup batteries became depleted on the next day or day after that, we lost transmission over an increasingly wide area.

Oya: The disaster made people in Japan realize how dependent we have become on electricity, and how little we can do without it.

Shinohara: We too realized that we had left ourselves too

dependent on grid power supply, and we've since taken measures such as extending backup battery life by reducing telecommunications equipment electricity consumption and expanding our emergency power supply capacity. Also, we use vehicles equipped with satellite equipment to secure alternative routes during emergencies, and we've recently developed new satellite earth stations that are much more lightweight than previous equipment.

Oya: What are the advantages of reducing the weight?

Shinohara: The previous stations weighed about 100 kg, making them difficult for just one person to manhandle. The new earth stations weigh about 40 kg, and they can also be dismantled to carry in pieces, which means they can be taken out to where they're needed almost immediately after a disaster strikes. We also equipped them with new capabilities for automatically searching and tracking satellites, and so, unlike the earlier earth stations, the new ones can be operated even by people who don't have any special skills.

Oya: That sounds very useful, since there are almost never enough people on hand in emergencies. You certainly didn't waste any time in reducing the weight by over half.

Shinohara: Actually, our labs started about ten years ago to look into how to engineer more compact and lightweight equipment, and had already made big strides in component technology. Since the quake, our earth stations have been mobilized more often than before, and it was because our people in the field demanded that we make the equipment easier to manhandle that we got cracking on practical implementation.

Saving energy painlessly through enabling smart electricity utilization at local community level

Oya: You said that you've been working on reducing telecommunications equipment electricity consumption since the disaster. What targets did you set for the NTT Group as a whole?

Shinohara: The NTT Group accounts for about 1% of Japan's total electricity consumption. To fulfill our responsibility as such a high volume consumer and help create a low carbon society, we set ourselves the groupwide target of reducing electricity consumption in our office buildings and labs by 30% over the summer of 2011, and went at it tooth and nail. Of course, we made sure that we didn't take things too far and adversely affect our work.

Oya: Eliminating wastage doesn't necessarily require you to go overboard, does it? There's no point, after all, in turning off the air conditioner to save electricity at home if you end up suffering heat stroke as a result.



Shinohara: You're right. That's the principle at work behind the smart community initiative that we're pursuing — eliminating wastage and enabling smart use of electricity at the local community level without undue hardship. The idea is to link all electrical equipment in the homes and offices of a particular neighborhood through a data network with all sources of power within the neighborhood, including solar systems, wind turbines, fuel cells, batteries and electric vehicles as well as the local power utility grid, so as to enable optimization of electricity supply and demand at the local community level.

Oya: The output of solar and wind power systems fluctuates greatly with changes in weather, and that apparently makes a stable supply of power very difficult.

Shinohara: Yes, practical implementation will require the deployment of sufficient battery capacity and regulation of demand — in other words, the cooperation of households and businesses in saving electricity — to reduce electricity consumption when electricity is running short. That's why the NTT Group is creating mechanisms for visualizing electricity consumption by each appliance in the home or office so as to encourage people to conserve electricity, and developing the technology required for optimal control of the huge mass of electricity consumption data

generated within a community. We're also seeking to achieve the goals of our Group environmental vision, THE GREEN VISION 2020, by doing R&D aimed at reducing environmental impacts.

Oya: Technology for smart electricity saving would be immensely useful to society, so I think you should use every opportunity to tell people about your efforts.

Leveraging ICT to address healthcare and education issues

Shinohara: I'd like to talk also about our initiatives in the healthcare and education fields. We're currently conducting a trial in the village of Hinoemata in Fukushima Prefecture of a remote healthcare consultation system for elderly people. The system enables the only clinic in the village to provide elderly people with health maintenance advice through their TVs. We've also connected the clinic to nearby hospitals to enable the clinic's staff to consult with specialists about diagnosis and treatment of conditions as occasion demands.



Oya: Preventive healthcare can also help curb medical costs, so I hope you'll be expanding the service to cities too once the trials are completed.

Shinohara: In the field of education, we've developed a system called *Koemiru* (= "Visible Voice") that feeds the spoken word of teachers to a speech recognition server for conversion to text that can be displayed on student mobile devices or an electronic blackboard. Starting in January 2012, we conducted a three-month trial of the system in schools for children with hearing impairments in Tottori and Okinawa. Once the system is fully implemented, we're hoping it will enable kids with hearing impairments to attend ordinary schools.

Oya: It sounds like a very worthwhile system. What prompted you to develop it?

Shinohara: There's a company in the NTT Group called NTT CLARUTY that helps people with disabilities to participate in society, and we got the idea through talking with the company's employees.

Oya: So you could say it was an idea born out of engaging the outside world as well as lab work. I can't help feeling that all businesses should do likewise — that they need to go out and talk with all kinds of people. And when they do so, they also need to translate all those technical terms and so on into plain language that anyone can understand. No matter how outstanding your technology is, you won't be able to offer really useful services unless you can get people to understand its purpose or value. More than anything else, you won't be able to win the trust of others.

Shinohara: You're right. We will definitely take your point and do our utmost to engage in sincere dialogue with all kinds of stakeholders to continue creating valuable products and services. Thank you very much for your time today.

R&D aimed at building a robust communications infrastructure: Learning from the Great East Japan Earthquake

NTT Access Network Service Systems Laboratories

Developing new satellite communications systems that greatly reduce deployment time

Immediately after the Great East Japan Earthquake, NTT endeavored to secure communications in affected areas by deploying Ku-1ch miniature satellite communications earth stations to connect phone lines at key evacuation centers, as well as free temporary public phones that were hooked up to portable satellite communications systems that handle both phone and Internet traffic. However, these systems were outdated and required a lot of time to set up and adjust antenna angle and such like. The antenna units too were bulky and difficult to manhandle.

Fiscal 2012 developments

NTT Access Network Service Systems Laboratories (NTT ANSSL) succeeded in reducing both system size and weight by over half, also developing an antenna with a smaller dish that can, moreover, be split into four parts for carrying in a case. NTT ANSSL has also developed a new satellite communications system equipped with an automatic satellite signal acquisition capability that reduces antenna setup and satellite acquisition time to about one-sixth of previous systems. Both NTT East and NTT West plan to deploy the new system by the end of fiscal 2013.



Weight of new system: 40 kg



Weight of previous system: 100 kg

• Weight of antenna and control unit (excludes power supply and other auxiliary equipment)

NTT Network Service Systems Laboratories

Developing new technologies to cope with surges in network traffic

Because network traffic tends to surge after a major disaster or other emergency, network resources allocated according to the needs of voice, video, Internet and various other services need to be reallocated to ensure that as many people as possible can use critical communications services. NTT Network Service Systems Laboratories (NTT NSSL) and NTT Network Innovation Laboratories are working on the development of network virtualization control technologies required to enable such resource reallocation.

Fiscal 2012 developments

In November 2011, NTT NSSL announced that it had developed the world's first technology for building high-quality virtual networks with control capabilities for selecting and switching between optimum routes according to user requirements. In trials, NTT NSSL succeeded in building a wide-area virtual network that encompassed the whole northern hemisphere. This technology holds promise as a means for helping to keep services going in disaster situations by automatically resetting transmission routes to avoid damaged locations.

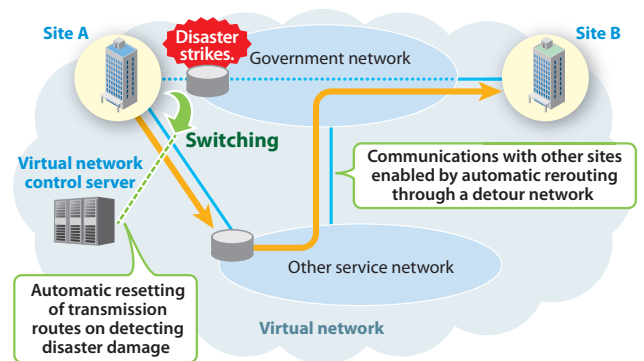

Example of network virtualization control technology application

Group company initiatives

NTTEAST

Initiatives prompted by the Great East Japan Earthquake

NTT East started implementing stopgap measures to restore communications in affected areas immediately after the Great East Japan Earthquake struck, and continues its efforts to complete full restoration. It is also applying the lessons learned from the disaster to implement measures for further improving the reliability of its services throughout eastern Japan so as to fulfill its mission to keep people connected in any contingency.

① Full restoration (affected areas)	Measures to surpass pre-earthquake service reliability levels	
	<ul style="list-style-type: none"> ① Relocation of destroyed communications buildings to higher ground ② Laying new trunk lines under riverbeds in locations where cables strung along bridges were swept away ③ Deploying bypass routes for trunk lines and switching parent stations of exchange buildings in the nuclear accident zone 	
② Measures to improve reliability	Measures to further improve service reliability	
	① Building disaster-resistant facilities	<ul style="list-style-type: none"> • Measures to prevent power outages and flooding of communications buildings • Improvements to the disaster resistance of trunk lines
	② Rapid restoration of communications services	<ul style="list-style-type: none"> • Building up stock of disaster response equipment • Integration of measures that proved effective after the Great East Japan Earthquake into disaster preparedness programs
	③ Securing communications immediately after a disaster	<ul style="list-style-type: none"> • Securing means of communication during emergencies • Supporting municipal services for local community residents

As well as marshaling its group strengths to restore and rebuild telecommunications networks in areas affected by the Great East Japan Earthquake, the NTT Group is focusing on R&D and business policies aimed at building more robust telecommunications infrastructure based on the lessons learned from the disaster. We report here on the progress status of key initiatives featured in last year's report.

NTT Network Service Systems Laboratories

More advanced disaster message board services that enable simple registration and checking of information

After the Great East Japan Earthquake, many people used Disaster Emergency Message Dial (171) and other safety status checking services, but some were also confused by the multiplicity of such services, and complained that entering information on the Disaster Emergency Broadband Message Board (Web 171) service was difficult and so forth. To address this situation, NTT Network Service Systems Laboratories (NTT NSSL) and NTT Service Evolution Laboratories are currently conducting R&D to develop simpler and more convenient safety status checking services.

Fiscal 2012 developments

NTT NSSL developed improvements to the Web 171 service, including one-stop search of safety status information of other mobile and PHS carriers as well as the NTT Group, and a function for sending e-mail or voice messages to registered destinations when posting safety status information. NTT made the new functions available on August 30, 2012.

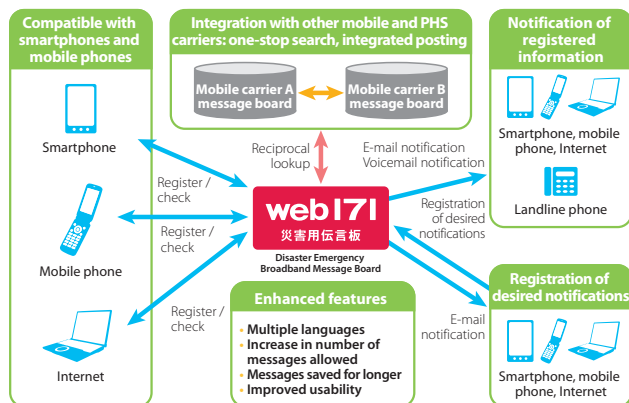

NTT Software Innovation Center

Developing backup technologies for prompt restoration of services after large-scale disasters

Most businesses back up their data to guard against disasters, but in the case of large-scale disasters like the Great East Japan Earthquake, there is a chance that buildings housing backup data might also suffer extensive damage that results in loss of data, and prevents business continuity. NTT is accordingly conducting R&D into the prompt switching of operations back to disaster recovery sites to enable continued service provision in the event of a disaster or system overload.

Fiscal 2012 developments

In August 2011, NTT Software Innovation Center completed development of a remote live migration technology for migrating cloud service functions to a server in a different location without suspending the cloud service. It continues its efforts to make the migration of cloud services simpler and speedier than previous technologies so as to enable more customers to use them as means of guarding against disasters and other contingencies.

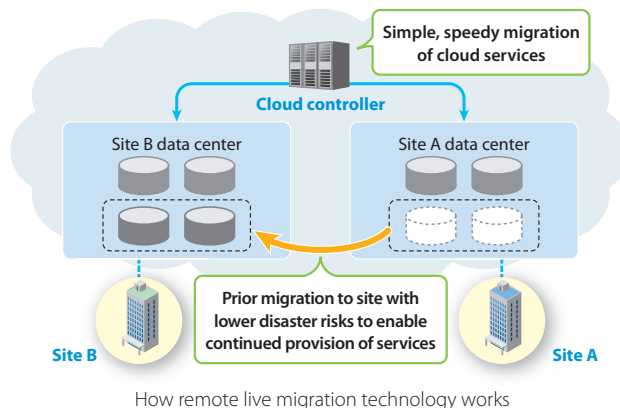

Leveraging the lessons learned from major disasters to formulate new disaster preparedness measures

The Great East Japan Earthquake caused extensive damage to NTT DOCOMO's facilities and services. In addition to applying all available resources to the restoration of affected areas, in April 2011 the company introduced new disaster preparedness measures under three basic policies based on the lessons learned from the earthquake. Almost all policy targets were achieved by the end of February 2012.

New disaster preparedness measures

- 1 Securing communications in key service areas**
Securing communications in heavily populated areas and for government agencies
 - ① Nationwide deployment of large-zone base stations (104 locations)
 - ② Equipping base stations with uninterrupted power and 24-hour batteries (approx. 1,900 stations)
- 2 Enabling rapid response in disaster zones**
 - ③ Immediate provision of satellite mobile phones to secure communications for evacuation centers etc. (3,000 phones)
 - ④ Use of satellite systems to rapidly secure communications coverage areas
 - ⑤ Use of emergency microwave entrance facilities to build flexible communications coverage areas (100 areas)
- 3 Improving usability of customer disaster services**
 - ⑥ Development and provision of Disaster Voice Messaging Service
 - ⑦ Upgrade of Restoration Area Map web page
 - ⑧ Addition of voice guidance to improve Disaster Message Board Service usability
 - ⑨ Promotion of Area Mail Disaster Information Service use
 - ⑩ Further promotion of ICT utilization by linking with social networking services etc.

Corporate governance

Ensuring sound management, decision making and business activities

Basic philosophy

As the holding company of the NTT Group, NTT believes that raising the effectiveness of corporate governance is an important management issue for maximizing corporate value and meeting the expectations of its various stakeholders.

Accordingly, NTT is working to strengthen corporate governance based on its fundamental policies of ensuring sound management, conducting appropriate decision-making and business activities, clarifying accountability and maintaining thorough compliance.

Board of Directors

NTT maintains a Board of Directors with 12 members, including two outside directors. The Board of Directors meets in principle once per month, also holding extraordinary meetings as occasion demands, to address matters specified by laws and regulations, take decisions on important holding company and group management issues as a holding company responsible for overseeing and coordinating the NTT Group, and supervise the execution of duties of individual directors by having them provide regular status reports.

Board of Corporate Auditors

NTT's Board of Corporate Auditors has five members, three of whom are outside corporate auditors. In addition to attending Board of Directors meetings and other important meetings, corporate auditors audit the performance of NTT's directors in the execution of their duties as they see fit. The corporate auditors also work to bolster auditing functions through maintaining close contact and regularly sharing information on audit plans and audit results with the Independent Auditor, and they share information with NTT's Internal Control Office and question it about the results of internal audits. The Board of Corporate Auditors works with the auditors of group companies to conduct audits.

Executive Officers Meeting and committees

In principle, important company matters are deliberated and decided by NTT's Executive Officers Meeting, which is made up of the President, Senior Executive Vice Presidents, full-time directors and the heads of staff organizations. Executive Officers Meetings are held once a week in principle. One corporate auditor also attends these meetings to boost the transparency of decision making. Under the Executive Officers Meeting, committees have been created to discuss specific issues related to the management strategies of NTT Group companies. In principle, each committee is chaired by either the President or a Senior Executive Vice President, with other directors and senior executives involved in relevant areas participating in meetings held throughout the year as occasion demands.

Internal control systems

NTT is working to strengthen the Group's internal control systems with the Board of Directors adopting a Basic Policy on the Maintenance of an Internal Control System to ensure the appropriate execution of duties within each group company. In line with the U.S. Public Company Accounting Reform and Investor Protection Act (Sarbanes-Oxley Act) and Japan's Financial Instruments and Exchange Law, NTT is working to document business processes and conducts repeated tests to confirm the effectiveness of its financial reporting internal control system. The Internal Control Office monitors the status and operating effectiveness of internal controls across the Group as a whole through such measures as conducting standardized audits that target all group companies and checking the work of internal auditors in each group company, as well as implementing improvements to the Group's internal control systems.

Defining accountability

NTT strives to maintain appropriate, timely and fair information disclosure, and is aware that obtaining proper corporate valuations in the market through such disclosure is essential. It accordingly holds press briefings, discloses information promptly on its website, and otherwise endeavors to define accountability.

Corporate governance structure (including an outline of the internal control system)

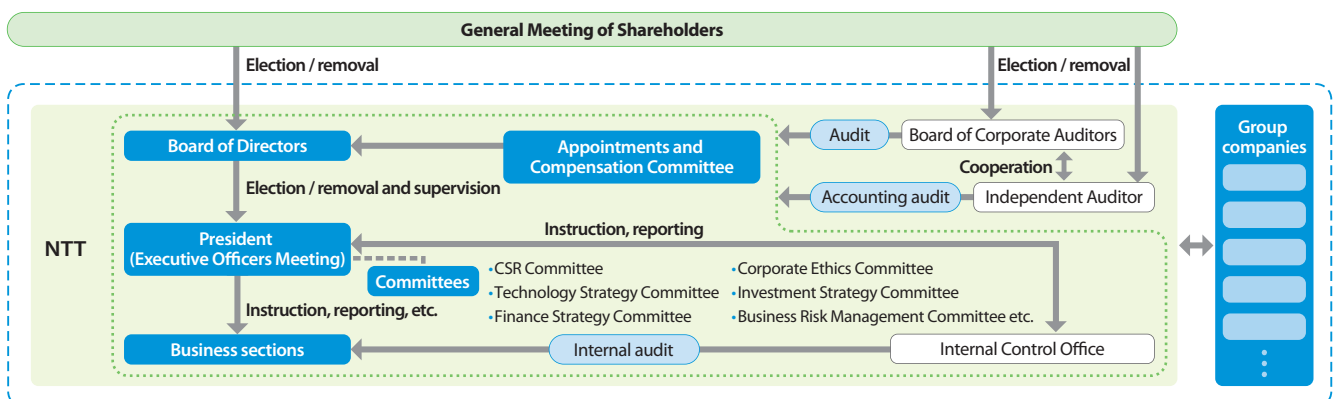

Ensuring compliance

The NTT Group runs its businesses in compliance with its Corporate Ethics Charter.

Recognizing that it is imperative to conduct business in compliance with laws and regulations, and maintain the highest ethical standards in order to promote sound corporate activities, NTT drew up the NTT Group Corporate Ethics Charter in November 2002.

The Charter, which applies to all officers and employees of the NTT Group, lays out the basic principles of corporate ethics and provides specific guidelines for ethical behavior. To ensure that the Charter is effective, NTT strives to raise employee awareness of its goals by providing training in corporate ethics and conducting

annual employee attitude surveys. In fiscal 2012, 98.8% of its employees received this training.

To prevent dishonesty and misconduct, each company has in place a system for employees to report and consult on ethical issues. NTT has also established a groupwide Corporate Ethics Help Line to enable employees to go outside their company for help if required.

In line with Japan's Whistleblower Protection Act and other laws, NTT also accepts reports from companies outside the Group that do business with the NTT Group.

Preventing misconduct following the arrest and prosecution of an NTT East employee



The NTT Group recognizes that compliance is an absolutely critical aspect of ensuring its sustainable growth and development together with its stakeholders through fulfilling our social responsibility, and it has implemented various measures to establish high corporate ethical standards.

Despite such efforts, an NTT East employee was arrested and prosecuted in March 2012 on suspicion of violation (accepting a bribe) of the Law Concerning Nippon Telegraph and Telephone Corporation, Etc. (hereafter, the NTT Law) for accepting money from a subcontractor in relation to his work. We humbly apologize for this truly regrettable incident. (Employees of NTT, NTT East and NTT West are not public servants per se, but owing to the public nature of their work, they are deemed to be public servants and treated as such with respect to criminal punishment.)

To ensure that no further such incidents occur, we are intensifying employee education. NTT East in particular has redoubled its efforts to raise awareness of corporate ethics through re-educating all employees in every workplace on the NTT Law and the importance of compliance. In addition to bolstering educational measures such as employee training and the display of posters, it implemented a number of immediate measures, including workplace meetings and screenings of educational videos on corporate ethics.

We will do our utmost as the NTT Group to further raise awareness of corporate ethics and compliance with relevant laws, regulations and company rules so as to cultivate high ethical standards and sound corporate conduct, and enable all of our employees to carry out their work with pride, confidence and sincerity.

Risk management system

The NTT Group has a framework to prevent risks and to minimize the impact of any risks that do emerge.

Functioning as they do in a rapidly changing business climate marked by increasingly fierce competition in the fields of information and communications, NTT Group companies face a wide variety of business risks.

We make efforts to anticipate and prevent potential risks at hand and minimize the impact should they emerge. As part of these efforts, we have prepared a standard manual for distribution

to all group companies to ensure a unified approach to risk management. Each group company also prepares its own manual or other mechanisms tailored to its specific business activities and environment to manage and mitigate business risks.

Human rights awareness

We make groupwide efforts to raise human rights awareness and create a corporate culture that respects human rights and is free of any discrimination or harassment.

Based on the Universal Declaration of Human Rights and other references, NTT has long endeavored to address the Dowa problem (discrimination based on ancestry in Japan) and other human rights issues, and create a corporate culture opposed to any form of discrimination. To take an even more proactive approach to respect for human rights in the light of growing awareness of their importance worldwide, we established our Basic Policies on Human Rights in June 2012.

Furthermore, all NTT Group companies provide workshops, e-learning courses and other programs that enable employees to learn about these issues on a multifaceted continuing basis. Other activities to boost and establish awareness of human rights include soliciting slogans and ideas for posters promoting awareness of human rights from NTT employees and their families, the best of which are compiled into calendars and distributed around the workplace.



NTT Group human rights awareness booklet

Key initiatives of group companies

NTT East

NTT East calls on its group company employees and their families to create human rights posters and slogans. In fiscal 2012, 487 posters and 86,754 slogans were submitted.

NTT Communications

NTT Communications is endeavoring to create cheerful and lively workplaces. In fiscal 2013, it started to use video streaming to provide human rights training in the form of a seminar on harassment and the Dowa ancestry discrimination issue to all 12,000 of its employees, including temporary staff. It also established its annual call for human rights slogans as a policy for the whole NTT Communications Group, including overseas group companies, and received a number of slogans from overseas subsidiaries.

NTT COMWARE

In fiscal 2013, NTT COMWARE plans to hold workplace study sessions aimed at further raising employee awareness of human rights. In these sessions, examples of human rights issues will be presented for employees to cultivate mutual understanding through discussion and an exchange of views on the issues raised. NTT COMWARE is making preparations to establish these study sessions as a policy, and hopes to use them also as a means for nurturing workplace communication.

NTT CLARUTY

In November 2011 and April 2012, NTT CLARUTY employees with disabilities met with the Industrial Federation for Human Rights, Tokyo to talk about the human rights problems that they themselves have had to deal with in the past. These meetings provided an opportunity for those attending to deepen their understanding of people with disabilities and revisit the subject of human rights.

Commendation from Osaka for child abuse prevention measure



NTT West endorses and cooperates with the city of Osaka's program for raising awareness of child abuse and its prevention. As part of its support for the program, from March 2011 it has been displaying stickers giving consultation hotline details in approximately 1,600 public telephone boxes and 4,200 public telephones in train stations, underground shopping arcades and elsewhere throughout Osaka.

The display of such stickers in public telephones is in principle prohibited, but NTT West obtained the permission of relevant authorities to implement this measure as the first of its kind throughout Japan.

NTT West will continue to do its utmost to contribute to local communities through such activities.

Prospering with our business partners

Working with suppliers to create outstanding services and reduce environmental impacts

To provide its customers with valuable services, the NTT Group uses cost-effective products and technologies, and practices green procurement, buying products designed to minimize environmental impacts. Building trust-based partnerships with suppliers is essential to implementing such policies.

We have accordingly published our Basic Procurement Policy since 1999, and create regular opportunities to listen to our suppliers. We also post procurement information on our website, and have procurement contact points in North America and Europe as well as in Japan for fielding inquiries and providing guidance on procurement.

Individual group companies are also implementing their own initiatives. NTT East and NTT West, for example, use check sheets to assess the way in which their suppliers meet their responsibilities to the environment and society. NTT DOCOMO also holds "Partner Get-Togethers" to forge closer ties with its suppliers, and NTT DATA holds Business Partner Presidents Meetings to exchange views with its business partners.

Basic Procurement Policy

When procuring products, NTT will:

1. conduct its procurement in an open and transparent manner, taking into account its business needs;
2. provide non-discriminatory and competitive opportunities to both domestic and foreign suppliers; and
3. conduct global and market-driven procurement of competitive products that meet its business needs.

The NTT Group Guidelines for Green Procurement

These Guidelines represent the NTT Group's basic stance on green procurement and set forth the general areas in which the NTT Group and its suppliers address environmental issues on a continuing basis.

WEB

Procurement information website
<http://www.ntt.co.jp/ontime/index-e.html>

Working with suppliers to promote socially responsible procurement

NTT
docomo

NTT DOCOMO pursues a policy of market-driven procurement, providing both domestic and foreign suppliers with non-discriminatory opportunities to supply competitive products. It has also established its NTT DOCOMO CSR Procurement Guidelines to promote respect for human rights, compliance with labor codes, assurance of safety and hygiene and other aspects of socially responsible procurement in supplier production processes.

NTT DOCOMO displays these guidelines on its website and holds supplier briefings to share the details of its procurement policies and guidelines. It also requires its suppliers to submit a CSR Procurement Check Sheet once a year, and asks suppliers to make improvements when needed.



Partner Get-Together

Business Partner program to build ties with suppliers

NTT DATA

NTT DATA outsources some of its software development jobs to subsidiaries and affiliated companies both in Japan and overseas, and certifies highly rated suppliers and those with outstanding track records as Business Partner (BP) or Associate Partner (AP) companies. Certification requires meeting certain standards with regard to compliance with laws, regulations and social norms, sound management, appropriate security, protection of the environment and other CSR areas.

Starting in fiscal 2010, NTT DATA has tapped certain of its BP suppliers as Core BP companies that share the benefits of an increase in business and stronger ties coming with the designation. As of March 31, 2012, NTT DATA had four Core BP, 35 BP and 97 AP companies.



Business Partner Presidents Meeting

R&D efforts in basic technologies

NTT conducts basic technology R&D activities in three laboratory groups while also developing practical applications with its group companies.

NTT has three laboratory groups: NTT Service Innovation Laboratory Group, NTT Information Network Laboratory Group and NTT Science and Core Technology Laboratory Group. These groups conduct a diversity of research and development, including world-class cutting edge basic research to develop optical and other new technologies, and research on next-generation network (NGN) platform technologies and the innovative communication services that such networks enable. NTT works closely with group companies to bring the R&D outcomes of its laboratories to early fruition in the form of new products, technologies and services.

Responding to changes in the market and user needs, we established new laboratories in April 2012 to conduct research on cloud technologies and security, and in July 2012, changed the names of some of our laboratories to better reflect their current R&D focus and more accurately communicate the mission and direction of NTT laboratories.

Protection of intellectual property

NTT protects the results of its R&D to maintain its competitive edge, but at the same time makes its intellectual property available to a wider audience by licensing technologies that would contribute to the development of industries and businesses as well as standardized technologies that are already used in society.

We also examine the third party rights of technologies used in our business to prevent infringement of third party intellectual property rights, and otherwise strive to comply with intellectual property-related laws and regulations and mitigate potential business risks by sharing information with our group companies.

No. of patent and utility model applications in Japan and overseas

Fiscal 2008	Fiscal 2009	Fiscal 2010	Fiscal 2011	Fiscal 2012
2,000	2,100	2,200	2,300	2,400

No. of Japanese and overseas patents held (as of the end of each fiscal year)

Fiscal 2008	Fiscal 2009	Fiscal 2010	Fiscal 2011	Fiscal 2012
14,500	13,900	13,700	14,000	14,500

R&D structure

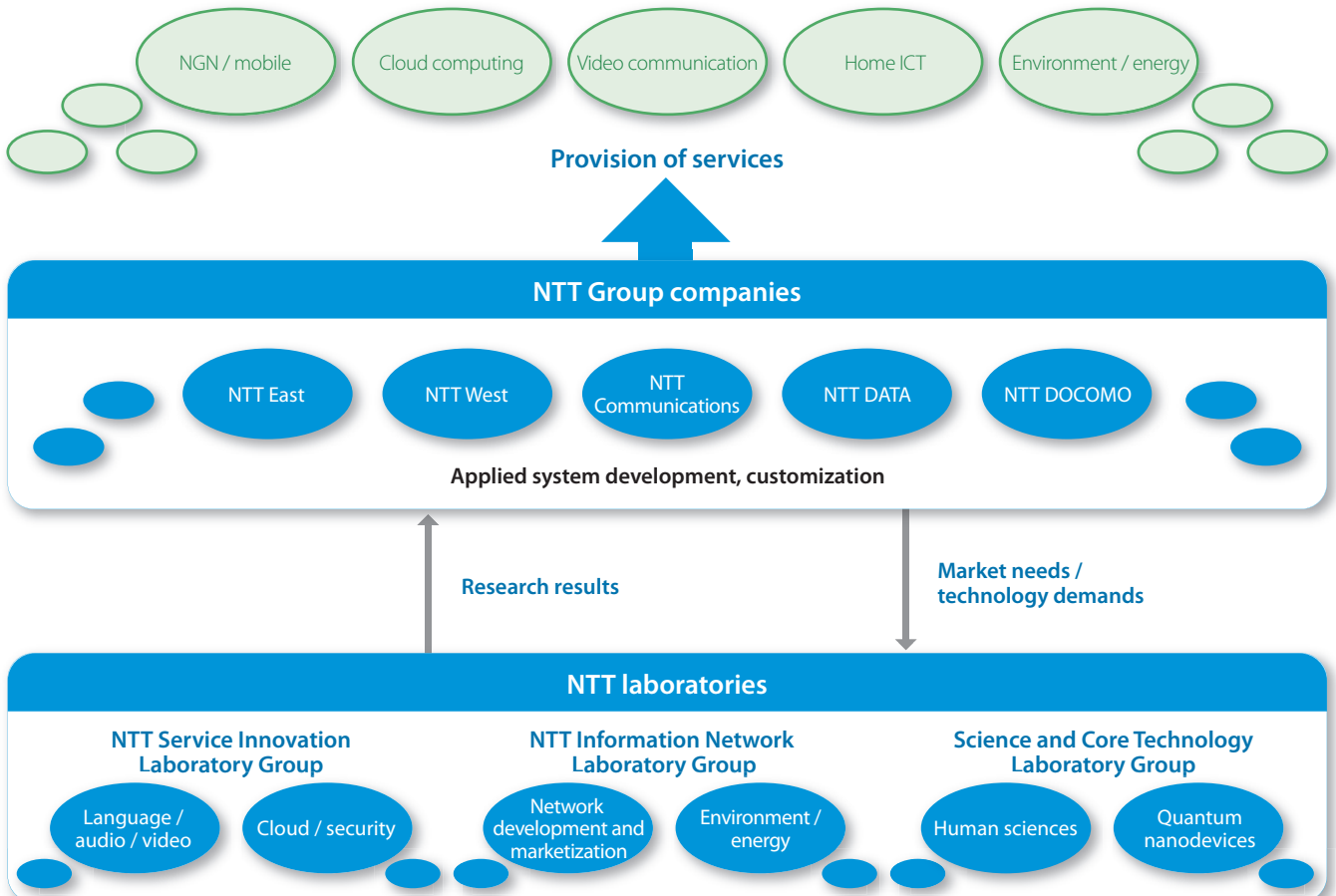

Communicating with our shareholders and investors

The NTT Group strives to improve management transparency through proactive disclosure and IR activities.

Basic philosophy

The NTT Group recognizes that enhancing its corporate value in the medium to long term and realizing appropriate returns to shareholders are crucial aspects of its business. At the same time, we are striving to improve the transparency of management through proactive disclosure and IR activities to enable our shareholders, investors and other stakeholders to appropriately evaluate our business performance.

NTT stocks

As a result of six offerings of government-owned shares since NTT's privatization in 1985, NTT stocks are in the hands of approximately 1.14 million* shareholders as of the end of March 2012.

*Including shareholders who own only shares representing less than one unit

Percentage of shares held according to shareholder category¹

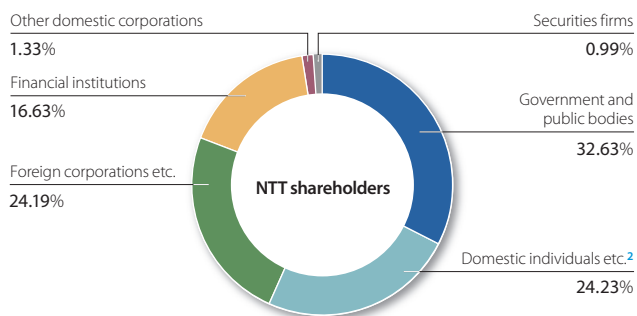

1. Not including shares representing less than one unit

2. Treasury stock included under "Domestic individuals etc." category

Returns to shareholders

NTT seeks to enhance returns to shareholders over the medium term. We determine the amount of dividends based on an overall consideration of factors such as business performance, financial position and dividend pay-out ratio, focusing also on stability and sustainability.

For the year ending March 31, 2012, NTT increased its yearly dividends by ¥20 to ¥140 per share. For the year ending March 31, 2013, NTT plans to increase its yearly dividends by a further ¥20 to ¥160 per share.

On July 5, 2011 and February 8, 2012, NTT acquired 99.33 million shares with a value of ¥381.7 billion as treasury stock.

Disclosure and IR activities

NTT has listed its shares on several domestic and foreign stock exchanges (Tokyo, Osaka, Nagoya, Fukuoka, Sapporo, New York and London), and has issued domestic and foreign bonds to procure funds. We consider it important to establish and maintain relationships of trust with our shareholders and investors in both domestic and foreign capital markets, and accordingly disclose information in a timely, appropriate and fair manner, fulfilling our accountability as a business corporation.

To help shareholders and investors to better understand our management strategy, we also actively conduct IR activities and create opportunities for our top management to directly communicate with our shareholders and investors by holding various events in addition to the General Meeting of Shareholders, such as IR road shows, briefings on specific themes, and briefings for financial analysts, individual investors and corporate bond investors, as well as participating in securities company conferences. We are also making efforts to enrich IR content on our corporate website.

Key IR activities

- We held a press briefing conducted by the CEO of Dimension Data, a focus of keen investor interest.
- We provided videos and PDFs of briefings for individual investors on an on-demand basis.



Briefing for individual investors

Listed on overseas Socially Responsible Investment (SRI) indexes

TOPICS

NTT has been highly rated by SRI evaluation organizations. As of April 1, 2012, we are listed on international SRI indexes such as Ethibel Sustainability Index (ESI) Excellence Global (Belgium).



Communication between people and their communities



Goal 1

Initiatives aimed at providing ubiquitous communications

Goal 2

Initiatives to promote participation in society

Goal 3

Involvement and cooperation in public policy

We are committed to leveraging ICT both to provide richer and more convenient communications, and to help address social issues in fields such as health and nursing care, education, environment, energy, security and disaster preparedness.





● Services to enrich everyday life

Peppering living spaces with sensors to create smart environments



Equipping consumer electrical appliances and other household items with sensors connected to networks could enable a huge mass of information on the status of a particular living space to be brought together, but for such systems to be feasible, the sensors would have to be extremely compact and maintenance-free (i.e. not require batteries).

NTT Microsystem Integration Laboratories (NTT MIL) is endeavoring to develop tiny battery-less sensors that could be embedded here and there throughout a living space to obtain various types of information. It has packaged test chips equipped with ultra-low power wireless circuits, nanowatt-level (10^{-9} watt) vibration detection circuits and such like into prototype devices, and is currently conducting proof-of-concept experiments on the technologies. In 2011, it developed a vibration detection circuit capable of running on just 0.7 nW, which is 1/600th of the power required by earlier circuits. This amount of electricity can be generated by an ultra-miniature photovoltaic cell measuring just 1-4 mm each way. The Japan Society of Applied Physics featured this achievement in the press preview for its 2011 Autumn Meeting.

NTT MIL is endeavoring to develop even lower power wireless circuits and ultra-miniature circuits of a few square millimeters that will enable the creation of smart environments*.

***Smart environment**

A physical world richly equipped with different kinds of smart device that constantly detect, measure, organize and utilize information related to all sorts of components within everyday living environments to make inhabitants' lives more comfortable.

● Services for supporting medical treatment and health management

Launching a cloud-based remote health consultation service that uses videophones



In recent years, mountainous regions and other areas with increasingly aging populations are suffering from a shortage of medical resources and preventive healthcare, problems that are compounded by other serious issues such as the increasing size of areas that public health nurses are required to cover and a decline in means of transport available to elderly people. Even in cities, the number of households composed only of single elderly people or elderly couples has grown rapidly, and the resulting isolation of elderly people has become an urgent issue.

Such circumstances are driving a growing demand among local authorities and medical facilities for ICT-based solutions for linking geographically separated locations to provide remote health guidance opportunities. To address this demand, NTT East has been providing a remote health consultation system since 2009.

And in September 2011, it also started to offer a fixed-price cloud-based remote health consultation service that combines NTT East's FLET'S HIKARI NEXT high-quality next-generation network (NGN) Internet access service with HIKARI DENWA phone service, FLET'S PHONE videophones, and a cloud-based health consultation service provided by NTT IT.

We will continue to offer ICT-based systems that enable the efficient provision of health advice and individual health guidance.

How the cloud-based remote health consultation service works

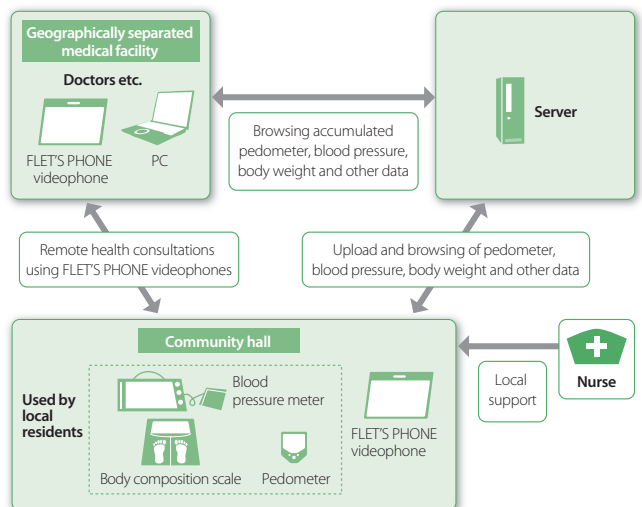

• NTT East helps to operate this system by building the remote health consultation system and providing its networks.



● Services for supporting medical treatment and health management

Providing remote health consultation services for areas with aging populations and a shortage of doctors



Many parts of Japan are currently having to cope with an increasingly aged population and shortage of doctors. A major problem is that people in such parts can no longer easily consult doctors when feeling under the weather. To address this problem, NTT Network Technology Laboratories (NTT NTL) has developed a remote health consultation system that enables the easy registration of data from instruments such as pedometers, weight scales and blood-pressure meters, and effective remote health consultations using videophones.

The system has already been deployed in the city of Tono in Iwate Prefecture and several other municipalities, and is being used at community centers to improve the health of local residents and to consult doctors. By stimulating communication among local community members, the system also helps to improve quality of life.

In fiscal 2012, NTT NTL developed healthcare service data entry and data sharing systems that comply with the Continua Design Guidelines, the global standard for health data distribution. This will enable simpler and more convenient health management and cooperation between services. These achievements are being applied to the remote healthcare consultation system trial currently in progress in the village of Hinoemata in Fukushima Prefecture, and to the remote healthcare solution joint trial with the Kameda Medical Group.

NTT will test the effectiveness of the new systems through these trials, and hopes to contribute to society by also examining the cost reduction benefits that these systems could bring through streamlining healthcare processes.



Remote health consultations in Tono City, Iwate Prefecture

Developing a platform for sharing and utilizing medical and personal health information



The sharing and utilization of electronic health records (EHRs) over networks is being eyed as a means of curbing Japan's constantly rising healthcare bill. Medical treatment and health information tends to be scattered among multiple hospitals, clinics, pharmacies and other facilities, and proactively integrating this information holds promise for avoiding unnecessary examinations and raising treatment quality.

NTT Network Technology Laboratories (NTT NTL) has developed a platform for integrating EHR systems for sharing patient medical records between medical facilities with personal health record (PHR) systems for sharing day-to-day personal health information among healthcare businesses. Integrating these two types of system with their differing security requisites has enabled the safe and secure sharing of scattered medical treatment records and personal health logs.

NTT NTL now plans to conduct R&D on enhancements to platform maintenance and applicability to different fields of medicine that are deemed necessary for community healthcare system revitalization, post-disaster reconstruction and other applications.

Medical and personal health record sharing platform overview

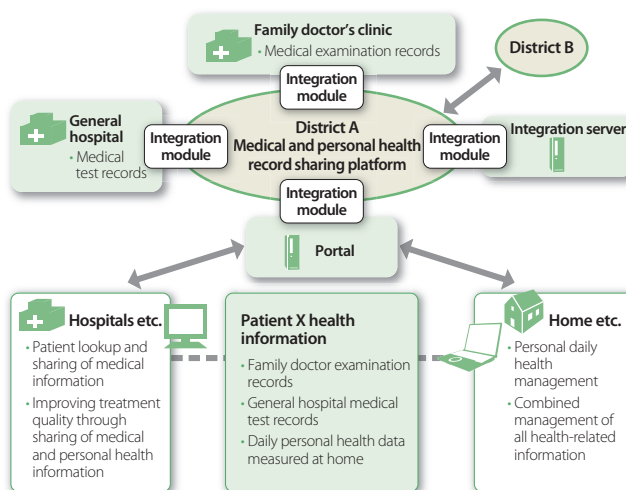



● Services for supporting medical treatment and health management

Launching trial of a cloud-based remote health guidance service that use videophones



As Japan's aging population drives up medical costs, many corporate health insurance unions are operating at a loss. Reducing medical costs through disease management and preventive healthcare is urgently required to keep corporate health insurance systems going, and ICT is expected to play an increasingly important role in such efforts.

The NTT West Group and Yodogawa Christian Hospital are seeking to address this issue by launching a trial of a cloud-based remote health guidance service that uses videophones, with the aim of testing the efficacy of such guidance and developing new services for providing individual health guidance in corporate health checkup programs.

Incorporating NTT West's Remote Health Consultation Service into its corporate health checkup individual guidance program will enable Yodogawa Christian Hospital to efficiently gather and visualize daily health data from company employees receiving guidance, and to aggregate this data so as to provide better guidance.

The trial will also look at the benefits of using videophones for remote health guidance from the perspectives of getting guidance recipients to make a habit of watching their health, and reducing time and effort involved in such guidance on both sides.

The NTT West Group is providing its Remote Health Consultation Service, which combines its FLET'S HIKARI NEXT high-quality next-generation network (NGN) Internet access service with HIKARI DENWA phone service and FLET'S PHONE videophones to streamline the provision of individual health guidance and support the provision of high-quality health diagnosis, consultation and improvement programs through the use of accumulated daily health data.

During the trial, NTT West plans to identify system requirements for the smooth provision of high-quality health guidance and test the communications performance of health information terminals, gathering feedback from Yodogawa Christian Hospital and participating corporate health insurance unions as it does so.

Remote health guidance service trial

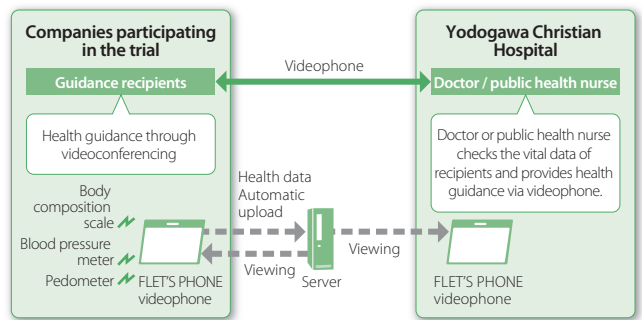



● Education services that offer added value

Field trial for Education Square x ICT project to connect schools with households



The NTT Group has contributed to the creation of one of the world's most advanced broadband environments through driving the spread of broadband services in recent years. In this context, it also created NTT Education LLP in October 2010 and launched a three-year field trial for the Group's Education Square x ICT project in the first quarter of fiscal 2012.

The trial is being conducted in line with national public school education computerization policies, with the cooperation of ten elementary and junior high schools in five municipalities nationwide as well as education experts and education industry businesses. Students gain by being provided with a safe environment that makes learning fun, while teachers not only find the system easy to use, but also benefit from being able to provide instruction attuned to the personality and capabilities of each student.

Education Square x ICT overview

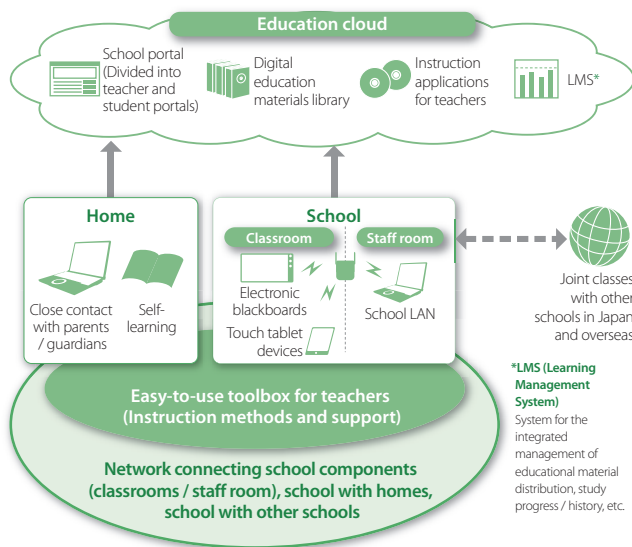

The fiscal 2012 trial got off to a good start, with the model classes and remote classes between schools and other facilities that had been developed by the education experts and businesses proving to be easy for the teachers to use and well received by all.

To further develop the project, two priorities were set for fiscal 2013. One of those is to promote the use of ICT in everyday classes by getting teachers to leverage the knowledge and skills gained from holding the model classes to make more use of ICT in all of their classes. The other priority is to enhance home study by developing new ICT-based formats and exciting educational materials that will grab the imagination of students and motivate them to study enthusiastically at home. We are aiming also to drive the effective adoption of ICT in public education by identifying any issues related to its use on both teacher and student sides.



WEB Education Square x ICT
http://www.ntt-edu.com/index_e.html



● Education services that offer added value

Partnering with Benesse Corporation to launch *Shimajiro Hiroba* service for families with growing children



NTT DOCOMO and Benesse Corporation launched *Shimajiro Hiroba x docomo community* as a joint trial service in April 2011. The service attracted about 160,000 users by the end of March 2012, making it the most popular free Google Play education application in Japanese in terms of downloads.* Based on the results of this trial, *Shimajiro Hiroba* was launched in April 2012 as a free service for smartphones, tablets and other devices, targeting families with growing children.

Shimajiro Hiroba features educational content linked to Benesse's *Kodomo Challenge* distance learning materials, as well as functions for uploading and saving photos of one's children, news related to raising children and other content. Moving forward, NTT DOCOMO and Benesse plan to add free content such as a *Family Connection* function for parents to share the photos and learning history of their children, and paid content such as *Learning Village* that each child builds according to learning progress, along with learning games, videos, and other premium content in the fields of expression, sociability, health and study.

*Placed No.1 among free educational apps from August to October 2011



Kodomo Challenge free edition



Omoide Kiroku children's photo album service

©Benesse Corporation 1998-2012 / Shimajiro

● Services for supporting business growth

Building data centers to support cloud services



In addition to NTT East and NTT West, the NTT Group includes a number of companies that build data centers and provide 24/365 data center operation, maintenance and security services. We take every precaution to ensure safe operation of our data centers, including quake proofing, uninterruptible power supply, and entry and exit control. In recent years, we are also building data centers to support cloud services, operating public clouds to provide computing resources that are shared by multiple businesses, private clouds to provide resources shared by different sections and systems of a single enterprise, and other types of cloud.

In fiscal 2012, we used an NTT East data center to conduct a joint field trial with Minami Sanriku, a town in Miyagi Prefecture that was devastated by the Great East Japan Earthquake. The trial involved installing a relay server and communications equipment in Miyagi Prefecture as the user site, and testing online backup to backup servers located in Tokyo. The idea behind using a relay server was to reduce impacts on customer systems. System nodes in Miyagi Prefecture and backup data nodes were connected respectively through the secure FLET'S VPN WIDE and Business Ether WIDE closed network services. Based on the results of this field trial with Minami Sanriku, the NTT Group started in June 2012 to use NTT East's cloud infrastructure to provide two types of Biz Hikari Cloud service — Safe Data Backup and Safe Server Hosting. NTT West is also offering the same services.

We will continue our efforts to bolster the business continuity of our customers through combining optical networks and data centers to deliver both convenience and reliability.

Field trial using data centers

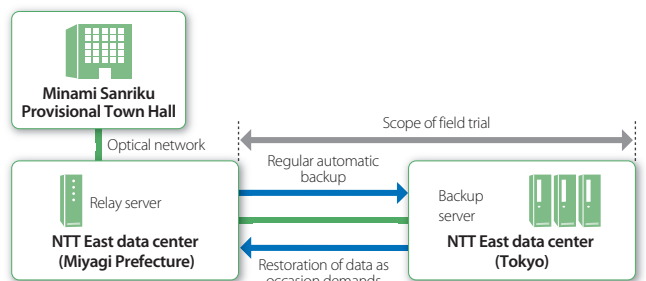



● Services for supporting the everyday lives of elderly people and those with disabilities

Mobile Phone Safety Program classes for elderly people to address the needs of an aging population



To address the needs of an aging population, NTT DOCOMO has since 2009 been dispatching instructors to local community associations and other organizations to hold Mobile Phone Safety Program classes for elderly people.

The classes are composed of two parts, with the first part devoted to coaching elderly people on how to avoid becoming the victims of bank transfer fraud and other crimes targeting them, and the second part devoted to explaining the Disaster Message Board Service, Area Mail Disaster Information Service and other mobile phone services for protecting people during disasters, and also what to do on misplacing a mobile phone and such like.

NTT DOCOMO also posts the educational materials used in its Mobile Phone Safety Program classes on its website so as to enable as many people as possible to learn about safe and secure mobile phone use.

WEB

Mobile Phone Safety Program educational videos

http://www.nttdocomo.co.jp/corporate/csr/social/educational/safety/movie_manual/index.html (in Japanese only)

Providing Housing with Specially Modified Facilities for the Elderly*



NTT Urban Development opened WELLITH Olive Shinkoiwa in Tokyo's Katsushika Ward in May 2010 as housing designed to enable elderly people to live safely and securely, but in conjunction with the 2011 revision of the Act on Securement of Stable Supply of Elderly Persons' Housing, it enhanced services and in February 2012 changed the building's registration from Good Quality Rental Housing for the Elderly to Housing with Specially Modified Facilities for the Elderly.

WELLITH Olive Shinkoiwa offers housing on par with most condominiums, while also paying meticulous attention to the needs of elderly people. For example, apartments are all fitted with emergency call systems and life rhythm sensors that automatically notify management when no sign of activity has been detected for a certain period of time. The building has a concierge counter for handling home deliveries, dry cleaning and other items, and providing shopping/free delivery service and other everyday assistance.

It is also equipped with a dining room and lounge, theater room, communal bathrooms with Japanese cedar tubs and other facilities designed to provide residents with comfort, convenience and plentiful opportunities to mix. The building's management watches out for the wellbeing of residents by calling in on them every day when picking up garbage, and prevents them from becoming isolated by organizing events such as firework displays, and supporting hobby groups and other activities that encourage them to get out and enjoy each other's company.

It also surveyed resident needs, and as a result introduced round-the-clock manned management service in April 2012, and opened a Nursing Care Office within the building in September 2012 to provide for a wider range of elderly care needs.

***Housing with Specially Modified Facilities for the Elderly**

Barrier-free housing for the elderly with specially modified facilities provided through cooperation with medical and nursing care services. Established as a new category in the 2011 revision of the Act on Securement of Stable Supply of Elderly Persons' Housing to drive the construction of housing in which elderly people can live with peace of mind.



WELLITH Olive Shinkoiwa



- Services for supporting the everyday lives of elderly people and those with disabilities

Developing teleworking mechanisms that make it easier for people with visual impairments to engage in work

 **NTT**  **NTT IT** NTT CLARUTY CORPORATION

NTT Service Evolution Laboratories, NTT IT and NTT CLARUTY are working together to create teleworking mechanisms that make it easier for people with disabilities to engage in work.

For example, they equipped the service menus of two services — MagicConnect, which enables safe and easy access to a company computer from a remote location, and MeetingPlaza, which enables videoconferencing and teamwork over the Internet — with text-to-speech functionality for the benefit of people with visual impairments.

User experiments were conducted in which people with visual impairments actually used MagicConnect and MeetingPlaza to test teleworking and identify remaining issues such as whether system functions and performance were sufficient to enable online conferencing from the home, and whether the system is easy for people with disabilities to use.

The results of these experiments are being used to consider improvements such as enabling the reading out of adjustment function menus required for dealing with errors.

Easy-to-use universal design phones for elderly people and welfare uses

 **NTTEAST**  **NTTWEST**

NTT East and NTT West released their Howdy Yu V and Silver Phone Hibiki S III phones on October 7, 2011. Both models boast standard features such as a function for adjusting the volume, quality and speed of the other party's voice during a phone call according to preference, quasi-broadband features, and a function for refusing nuisance calls.

The Howdy Yu V's receiver is equipped with an anti-howling function for preventing howling in the hearing aids of customers using them. The Hibiki S III is equipped with a bone conduction receiver for customers with hearing impairments.

Options for both phones include a pendant-type Wi-Fi emergency notification device and cordless handsets. A bone conductor handset is also available for the Howdy Yu V for use by customers in locations where the other party's voice is difficult to hear.



Howdy Yu V

Silver Phone Hibiki S III



● Expanding work opportunities

Rehiring former employees eager to work again



Many former group employees who gave up their jobs because their spouse was transferred elsewhere and other similar reasons are eager to return to work at the NTT Group. To address such aspirations and also leverage valuable experience and skills gained while working for the Group, we have established a system for rehiring former employees.

This system is open to former employees who left after March 31, 2010, had worked continuously for over three years, and left their jobs as a result of marriage-related relocation or transfer/change of job of a spouse. Employees wishing to be rehired inform their immediate superiors on leaving their jobs in order to register under the system.

Registered former employees are contacted each year for six years after leaving our employment to ask about their desire to return to work. The decision to rehire those wishing to return to work is taken after they have gone through an interview, health checkup and other necessary procedures, and depends also on business and personnel circumstances.

Home-based telephone support and home visit staff positions offer women and elderly people more employment opportunities



NTT Com CHEO conducts training and certification testing related to the configuration and use of computers and the Internet. People who have achieved ICT skills certification are hired as CAVA (.com Advisor & Valuable Agent) staff who work as home-based telephone support and home visit staff for Internet service providers (ISPs). CAVA staff, who currently number about 1,900, include men as well as women who are raising children or caring for elderly relatives at home.

In fiscal 2012, NTT Com CHEO deployed new support tools to create a more convenient working environment for CAVA staff and improve customer communication quality. It has also implemented its own policy for supporting CAVA staff employment among single-parent households to supplement the childcare allowance for such households provided by the government since fiscal 2010. There are now people throughout Japan who are working as CAVA staff as a result of having received this support.

NTT Com CHEO is also working with local authorities to provide job seekers with ICT skills training, opportunities to earn qualifications, and support for employment as home-based teleworkers.

How home-based telephone support and home visit staff work

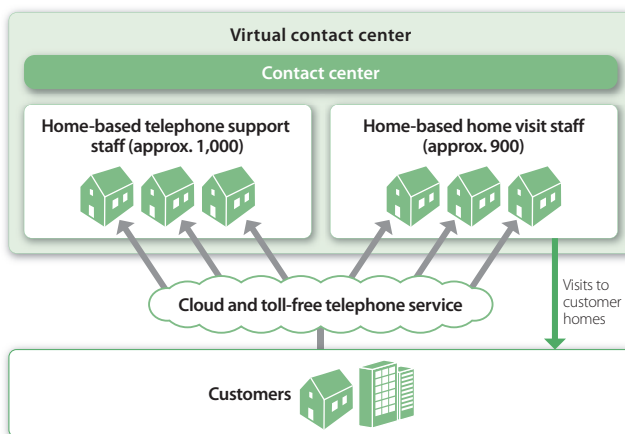



● Expanding work opportunities

Outsourcing company IT tasks on an hourly basis



NTT IT and Y's Staff Corporation on February 21, 2012, launched Smart Telework + IT Help Service for the easy outsourcing of various company IT tasks on an hourly basis.

Y's Staff, which has offices in Hokkaido and Nara, has 14 years of experience in telework management and a roster of 150 teleworkers working from home in locations throughout Japan. It launched an IT Help Service for companies to outsource minor IT tasks under a Ministry of Health, Labour and Welfare program to support teleworking by single-parent households and others, and has also trained teleworkers as part of efforts to support the employment of people in the 2011 Great East Japan Earthquake disaster zone. The two companies are pooling their strengths now to offer a service that addresses customer needs and concerns, and to enhance their respective services through collaboration.

An NTT IT Web conferencing solution is being used to visually monitor the progress of teleworkers on outsourced tasks, and ubiquitous remote access to ensure security by enabling work to be carried out on PCs and servers within the outsourcing company. Y's Staff is leveraging its long experience in teleworker management to handle teleworker education and management, with actual work being carried out by its 150 registered teleworkers, along with the teleworkers trained by Y's Staff under the initiatives mentioned above.

Smart Telework + IT Help Service overview

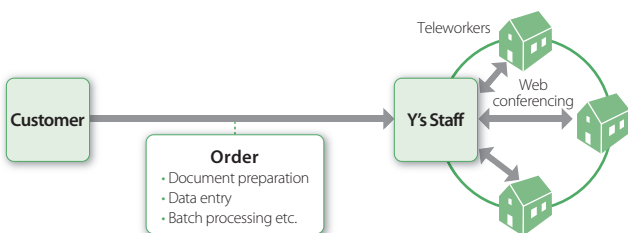



● Initiatives to eliminate digital divides

Hikari Life Support remote operation support services



NTT Service Evolution Laboratories has developed Hikari Life Support as a technology for enabling people who are unfamiliar with ICT to utilize various ICT-based home support services.

This technology enables the use of voice/video/text and other PC data output just through the use of a familiar phone number. Direct connection through a telephone number also ensures tight security, providing peace of mind when using services that handle personal data.

For example, senior citizens can receive health checks and advice without having to go through any difficult operations simply through calling a health advice center by phone, and then leaving it to the health center to display desired information on the PC screen and carry out other operations. The same technology can also be used to augment voice based explanations with video and other visuals when calling direct sales product description services or product support centers for help with settings or malfunctions.

In fiscal 2012, NTT standardized the way in which support information is sent and received, and prepared the ground for implementing Hikari Life Support on its networks. Moving forward, NTT plans to expand support information transmission formats to enable more advanced support.

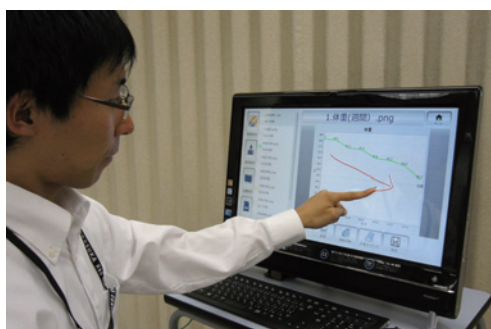

Showing each other materials and adding comments to them directly while communicating by voice

New service to help eliminate localities lacking broadband access



Based on the Ministry of Internal Affairs and Communications' strategy to bridge digital divides, field trials have been conducted in recent years to test 5 GHz band wireless access systems, WiMAX and other means of providing broadband access to remote islands and other locations lacking such access. However, radio wave transmission issues of various kinds need to be resolved when positioning stations, designing routes and building systems for long distances of up to several dozen kilometers. This requires both technicians equipped with expert knowledge and skills, and a great deal of time spent on researching and testing systems.

NTT Advanced Technology (NTT AT) accordingly leveraged expertise gained from providing ATSPOT, its existing comprehensive wireless solution support service, to launch a support service in June 2009 for eliminating the digital divides of remote islands and other isolated localities.

Through this service, NTT AT is currently helping local authorities, cable TV stations and others to establish transmission routes to remote islands. It has perfected its methods and shortened the time required for research and testing prior to the building of long-distance wireless systems, and provides one-stop support for all aspects from station positioning and route design to actual wireless system operation. It is also providing local authorities with proposals for wireless systems to prevent localities from getting cut off during disasters. These systems use mesh networks* and other means to make them better able to withstand disasters.

***Mesh network**

A network in which each node is connected to many others, configured to allow connections to be rerouted around broken or blocked paths, with the signal hopping from node to node until it reaches its destination.

Communication between people and the global environment



Goal 1

Environmental management

Goal 2

Creating a low carbon society

Goal 3

Implementing closed loop recycling

Goal 4

Conserving biodiversity

Based on THE GREEN VISION 2020, the NTT Group's vision for the environment, we are committed to reducing both the environmental impacts of our own business activities and those of society as a whole through providing ICT services. Group employees and their families also participate with local communities in a wide range of environmental protection activities.





● Basic policies and management system

Establishing a shared NTT Group charter and vision



In 1999, the NTT Group drew up its NTT Group Global Environmental Charter to formally define basic principles and policies for protecting the environment. Based on the fundamental principle that our business activities need to be compatible with protecting the environment, this Environmental Charter emphasizes the importance of combating global

warming and reducing waste and paper consumption, and established a set of targets for these priority activities to be achieved by fiscal 2011. In May 2006, we drew up the NTT Group Vision for Environmental Contribution, and based on the fundamental principle of contributing to reducing environmental impacts through providing ICT services, implemented various activities aimed at achieving our CO₂ reduction target for fiscal 2011. In November 2010, having met all of the above fiscal 2011 targets, we added the conservation of biodiversity as a basic policy to our Global Environmental Charter and drew up THE GREEN VISION 2020 as our new vision for the environment up to fiscal 2021.

The NTT Group's new vision for the environment up to fiscal 2021

THE GREEN VISION 2020

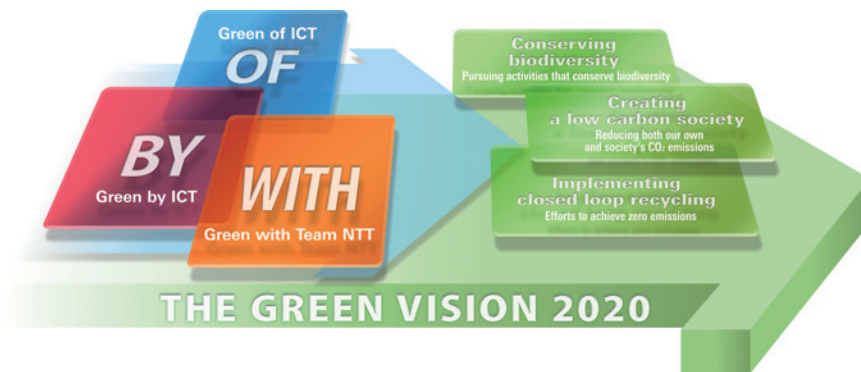

In November 2010, we formulated THE GREEN VISION 2020, our new NTT Group vision for the environment. Under this vision, we decided to focus our efforts on the three themes of creating a low carbon society, implementing closed loop recycling and conserving biodiversity, driving those efforts through the three approaches of “Green of ICT”, “Green by ICT” and “Green with Team NTT”. Particularly with regard to creating a low carbon

society, we are focusing both on reducing CO₂ emissions from our own business activities and on contributing to the reduction of CO₂ emissions of society as a whole through promoting the increasing utilization of ICT services.

All employees of the NTT Group are working as one to contribute to the sustainable development of society through achieving the goals of our new vision for the environment.



● Basic policies and management system

Environmental management

In fiscal 2006, the NTT Group established a CSR Committee charged with overseeing groupwide CSR activities, and brought the NTT Group Global Environmental Protection Promotion Committee, which drives group environmental protection activities, under the CSR Committee's jurisdiction.

The Global Environmental Protection Promotion Committee oversees the Greenhouse Gases Reduction Subcommittee and Waste Disposal and Recycling Subcommittee, directs groupwide projects implemented as occasion demands, formulates basic policies, manages targets and addresses any issues that emerge.

With the addition of the conservation of biodiversity as a basic policy to the NTT Group Global Environmental Charter, we established a new Biodiversity Working Group in fiscal 2011.

The NTT Group organization for promoting environmental protection

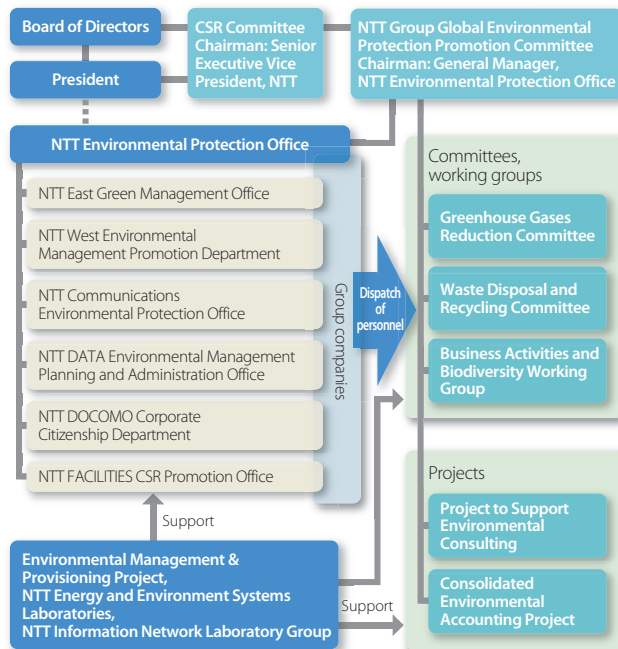

NTT Group Global Environmental Charter

Basic principle

To ensure the harmonious co-existence of people with nature and to achieve sustainable growth, we will do our utmost to protect the global environment in all our corporate activities.

Basic policies

- Compliance with laws and regulations and fulfillment of social responsibilities
- Reducing environmental loads
- Establishing and maintaining environmental management systems
- Developing environmental technologies
- Social contribution efforts
- Disclosure of environmental information
- Conservation of biodiversity



● Environmental impacts overview

Environmental impacts overview



To minimize the environmental impacts of its business activities, the NTT Group endeavors to gather and analyze information on the resources and energy that it consumes, the processes involved in that consumption, and the resulting environmental impacts.

The NTT Group endeavors to reduce its environmental footprint by quantitatively monitoring the environmental impacts of all processes of its business activities on a continuous basis, and by

setting itself concrete numerical targets under THE GREEN VISION 2020 for reducing CO₂ emissions, waste and paper consumption.

Of the 3.79 million tons of CO₂ emissions generated by the NTT Group in fiscal 2012, 3.74 million tons (approximately 99%) were derived from business operation-related electricity consumption.

Of the 784,000 tons of waste generated, 764,000 tons (approximately 97%) were recycled, and the remainder was incinerated, resulting in a reduction of 6,000 tons to leave 14,000 tons of final disposal waste.

Each year, the NTT Group issues 89.28 million telephone directories throughout Japan, which translates into 49,000 tons of paper. Of those 49,000 tons, 17,000 tons are from virgin pulp.

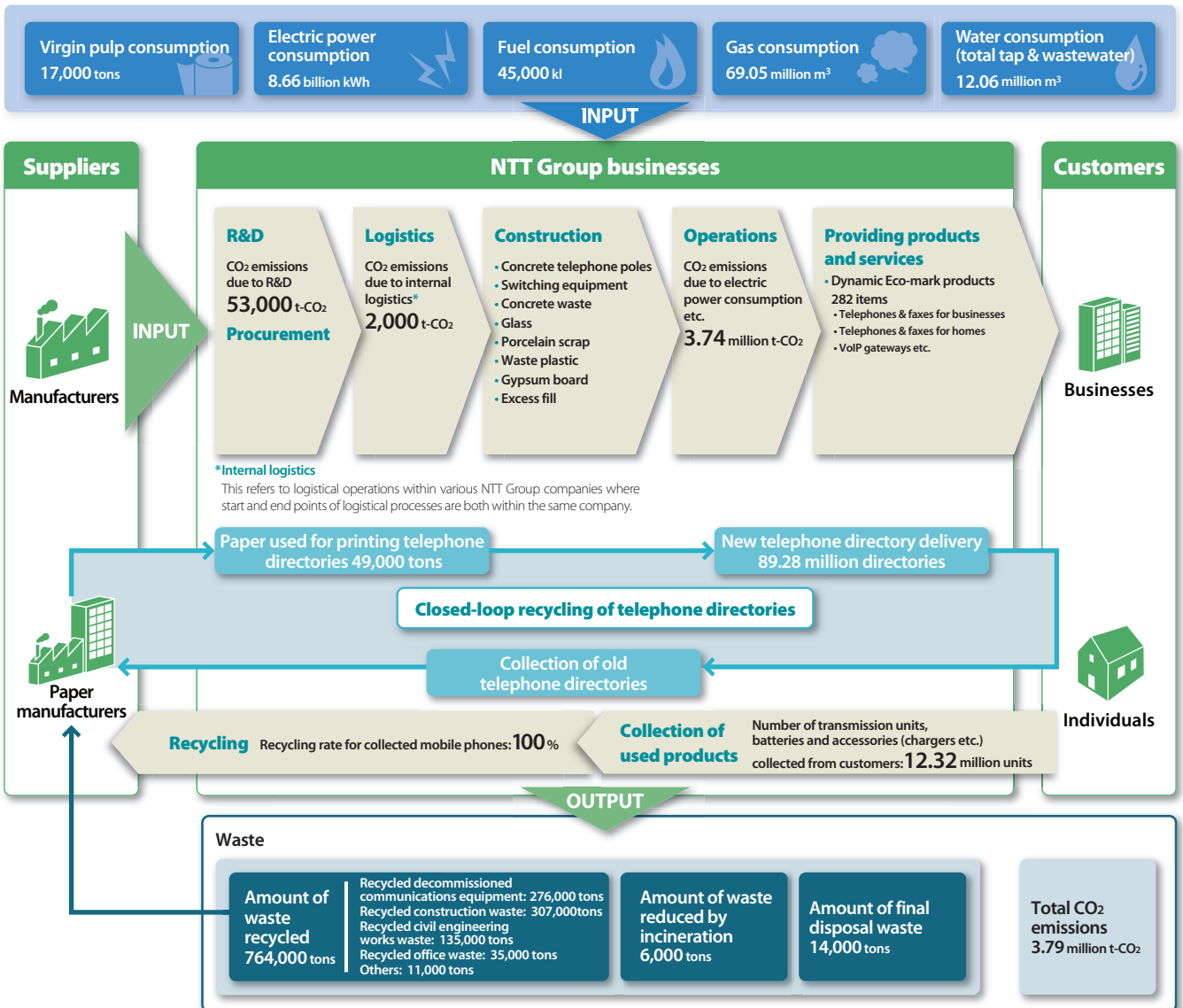



● Environmental accounting

Environmental accounting



The NTT Group introduced environmental accounting in fiscal 2001 to boost the efficiency and effectiveness of its environmental conservation efforts by quantitatively determining both the costs and benefits of environmental conservation programs undertaken as part of its business activities.

From fiscal 2012, we have endeavored to implement environmental accounting in line with our NTT GREEN VISION 2020. The Great East Japan Earthquake had the effect of driving up our environmental investment, but as a result of our communications equipment and building recycling efforts, we managed to generate an income of 7.31 billion yen.

Moving forward, we aim to implement even more efficient and effective environmental management through continued quantitative monitoring and analysis of our environmental activities.

1. Scope of data

The companies subject to consolidated environment accounting are NTT, NTT East, NTT West, NTT Communications, NTT DATA, NTT DOCOMO and their group companies (171 companies in total).

2. Applicable period

- Data for fiscal 2012 report is from April 1, 2011 to March 31, 2012.
- Data for fiscal 2011 report is from April 1, 2010 to March 31, 2011.

3. Accounting method

- Accounting is based on the NTT Group Environmental Accounting Guidelines. These guidelines comply fully with the Environmental Accounting Guidelines 2005 issued by the Ministry of the Environment.
- Environmental conservation costs are expressed in monetary units and benefits in monetary units and physical quantity.
- Environmental conservation costs are tabulated separately as environmental investments and environmental costs. From fiscal 2004, depreciation costs are included in environmental costs. Personnel costs are also included in environmental costs.
- Reductions in CO₂ emissions through energy conservation measures are calculated by subtracting actual emissions from projected emissions in the event that no such measures were taken.

Fiscal 2012 environmental accounting	Environmental investment (millions of yen)		Environmental costs (millions of yen)		Economic benefits (millions of yen)	Material benefits (thousands of tons)				
	Fiscal 2012	Fiscal 2011	Fiscal 2012	Fiscal 2011		Fiscal 2012	Fiscal 2011			
(1) Business area costs	11,870	10,700	19,150	19,640						
• Pollution prevention costs	410	480	640	630						
• Global environmental conservation costs	11,370	9,920	4,410	3,990	Cost reductions through energy conservation	5,850	5,390	Reductions in CO ₂ emissions through energy conservation measures	188	109
• Resource recycling costs	90	310	14,100	15,030	Revenues from sale of recyclable waste (decommissioned communications equipment, etc.)	7,310	6,400	Recycled decommissioned communications equipment	276	249
					Waste disposal cost reductions through recycling	0	0	Recycled construction waste	307	334
					Cost reductions through reusing decommissioned communications equipment	7,940	12,410	Recycled civil engineering works waste	135	158
					Cost reductions through reusing communications devices	13,010	13,680	Recycled office waste	35	41
					Cost reductions through reusing office waste materials	10	10	Other recycled items	11	12
(2) Upstream / downstream costs	110	10	6,440	6,040	Revenues from sale of recyclable waste (subscriber communications devices etc.)	230	330	Number of communications devices collected from customers (thousands)	12,320	16,071
					Cost reductions in postal expenses through computerization	5,120	4,680			
(3) Administrative costs	10	10	6,020	5,990						
(4) R&D costs	5,970	5,580	10,690	13,670						
(5) Citizenship activity costs	0	0	100	150						
(6) Environmental remediation costs	0	0	310	0						
Total	17,960	16,300	42,710	45,490		39,480	42,890			



● Green of ICT

Targets and results



Our group target for reducing CO₂ emissions to help create a low carbon society is to curb our emissions in Japan by at least 2 million t-CO₂ from the projected 2020 level so as to reduce total emissions by at least 15% (600,000 t-CO₂) from the fiscal 2009 level (using the Federation of Electric Power Companies of Japan's 0.33 kg/kWh as the emission coefficient for setting the fiscal 2021 target). Our CO₂ emissions for fiscal 2012 were 3.79 million tons, a year-on-year reduction of about 30,000 tons.

CO₂ emissions from business operations

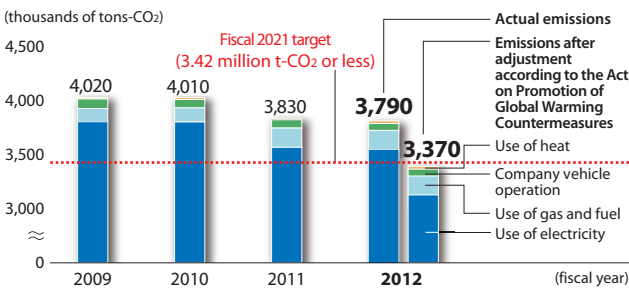

Fiscal year	2009	2010	2011	2012
Electric power (billion kWh)	8.68	8.72	8.71	8.66
Emission coefficient (kg/kWh)*	0.437	0.435	0.409	0.408
CO ₂ attributable to electricity consumption (thousands of tons-CO ₂)	3,793	3,791	3,558	3,531
CO ₂ attributable to gas and fuel consumption (thousands of tons-CO ₂)	121	129	177	177
CO ₂ attributable to company vehicles (thousands of tons-CO ₂)	88	77	76	66
CO ₂ attributable to heating (thousands of tons-CO ₂)	14	18	14	17
Total CO ₂ emissions (thousands of tons-CO ₂)	4,016	4,014	3,825	3,791

*Weighted average of emission coefficients announced annually by each power utility weighted according to the amount of each utility's power used by the NTT Group

Groupwide TPR campaign to reduce electricity consumption



Over 90% of the CO₂ emissions created by NTT Group business operations are attributable to office and communications equipment power consumption. The NTT Group accordingly created a groupwide energy conservation strategy called Total Power Revolution (TPR) in October 1997 to reduce its power

consumption. By promoting efficient energy management at buildings owned by NTT and installing energy-efficient electrical power units, air conditioning systems and telecommunications equipment, we managed to reduce power consumption across the NTT Group by 460 million kWh in fiscal 2012 compared with fiscal 2011.

Promoting Green NTT to expand solar power system deployment



The NTT Group has been implementing its Green NTT plan to promote the use of eco-friendly renewable energy since May 2008. The goal of this plan is to expand our use of solar power, which could be seen as a key symbol of the low carbon society. Our target is to deploy a total of 5 MW of solar power systems over the whole Group by fiscal 2013.

In August 2008, we established NTT-Green LLP, a limited liability partnership charged with the task of driving the Green NTT plan. NTT-Green LLP is pushing ahead with the efficient installation of solar power systems in premises owned by group companies, and by investing and participating in NTT-Green LLP, group companies can contribute to the spread of renewable energy use. With the approval of a third party certification authority, NTT-Green LLP also issues Green Power Certificates to investing companies, according to the amount of power generated in line with the amount invested. This is the first environmental project undertaken by a business group LLP in Japan that combines the deployment of solar power systems with the issue of Green Power Certificates.

In fiscal 2012, three new solar power generation facilities were added to the Group's stock, and went into operation. The eight facilities installed since fiscal 2010 generate a total of approx. 1.7 MW of power. These combined with systems deployed by individual companies brought the total number of NTT Group systems in operation nationwide to 161 as of the end of fiscal 2012, with a total generating capacity of about 4.5 MW. We are now almost within reach of our target of 5.0 MW by the end of fiscal 2013.

Moving forward, we will endeavor to continue to play a leadership role in contributing to the creation of a low carbon society through the expansion of renewable energy generation in Japan.

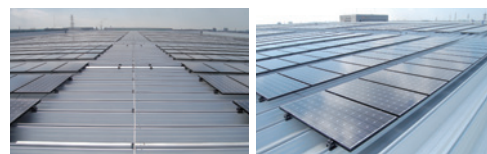

NTT LOGISCO Chiba Logistics Center



● Green of ICT

Establishing groupwide guidelines for the use of energy-saving ICT devices



The development and procurement of ICT devices with outstanding energy efficiency is essential to effectively reducing the CO₂ emissions of the NTT Group.

We accordingly organized our basic philosophy and device-specific targets with respect to the development and procurement of routers, servers and other ICT devices used in group companies into our NTT Group Energy Efficiency Guidelines, and we have applied these guidelines since May 1, 2010. These guidelines give concrete form to the ICT device-related energy-saving stipulations of our NTT Group Guidelines for Green Procurement and NTT Group Green R&D Guidelines.

Based on these Energy Efficiency Guidelines, group companies develop and procure ICT devices that pay due consideration to energy efficiency as well as to functionality, performance and cost. We are also endeavoring to apply this initiative to the reduction of electricity consumption and concomitant CO₂ emissions related to customer communications.

In August 2010, eight NTT Group companies¹ acquired the Eco ICT Logo on submitting self-evaluations of their CO₂ emissions reduction efforts, including the establishment of these guidelines. The Eco ICT Logo was created by the ICT Ecology Guideline Council² to signify efforts by telecommunications service providers to reduce CO₂ emissions.

Following the Council's announcement of its Ecology Guideline for the ICT Industry Version 3, the NTT Group revised its own Energy Efficiency Guidelines accordingly and announced Version 3 in February 2012.

1. The eight NTT Group companies are NTT Corporation, NTT East, NTT West, NTT Communications, NTT DOCOMO, NTT DATA, NTT FACILITIES and NTT COMWARE.

2. ICT Ecology Guideline Council:

An organization established jointly by the Telecommunications Carriers Association, Telecom Services Association, Japan Internet Providers Association, Communications and Information Network Association of Japan and ASP-SaaS-Cloud Consortium to drive industry-wide efforts to address the issue of global warming



Eco ICT Logo

World's first optical RAM chip composed of ultra-low power memory cells



With the exponential leap in the amount of data being handled across society today, servers, routers and other network equipment may soon be unable to crunch data at sufficient speed, and there are also concerns about the increasing amounts of power consumed by such equipment. Current network devices convert optical data transmitted through optical fibers into electronic data for processing, and this both increases power consumption, and acts as a brake on processing speeds. This is why researchers throughout the world are conducting R&D on enabling network devices to process data optically.

The biggest hurdles to enabling optical processing are the creation and integration of small enough optical memories, and minimizing the amount of power they consume. Using photonic crystals*, NTT Basic Research Laboratories and NTT Photonics Laboratories have developed an optical memory cell with power consumption over 300 times lower than previous records, and have also succeeded in integrating optical memory cells to create the world's first optical random-access memory (RAM) chip. By enabling optical data to be held and utilized as it is without converting it to electronic data, this achievement paves the way for creating much speedier network equipment that also consumes much less power.

NTT researchers continue to work on wafer-scale integration of optical RAM chips and their application to network equipment.

***Photonic crystal**

Crystals with a periodic structure and refractive index similar to the wavelength of visible light that can be fabricated in silicon or other semiconductors using standard nanofabrication techniques. Because photonic crystals act as optical insulators, they can trap intense light that escapes from conventional materials.



● Green of ICT

Developing a home ICT platform for saving energy in the home or office



With the rapid evolution and spread of network technologies in recent years, all sorts of devices — consumer appliances, audiovisual systems, housing equipment, sensors, etc. — in addition to PCs and other ICT devices have come to be connected to networks. In the past, lack of compatibility between the different connectivity specifications used meant that new network environments were required every time for the devices connected. To resolve this situation, the OSGi Alliance* created open specifications that enable interconnectivity and interoperability between network-enabled devices. In June 2012, the OSGi Alliance released its Residential specification for home networks.

NTT Service Evolution Laboratories is leveraging the experience it gained from leading the standardization processes to create the Residential specification to conduct research aimed at developing a general-purpose Home ICT platform that enables all sorts of devices in the household to interconnect and cooperate through a network.

The Home ICT platform is being eyed as technology for simplifying home and office network environments and saving both space and energy through the use of devices called home gateways for the unified distribution of services (software) required to use devices connected to the home network.

Home ICT Platform System STEP 1.5 released in fiscal 2011 was already equipped with the basic functions for distributing services to home gateways. These basic functions were refined, and a malfunction management feature for improving home gateway maintenance was added to the next version, Home ICT Platform System STEP 2.0, that was released in fiscal 2012.

Home ICT Platform System STEP 1.5 became commercially available in August 2011 as the FLET'S JOINT service offered by NTT East and NTT West.

***OSGi Alliance**

The OSGi Alliance is an organization established in March 1999 to standardize platform systems that enable the dynamic updating of Java modules.

Adaptive power saving control technology for creating eco-friendly optical networks



As awareness of environmental issues grows, telecommunications carriers are under increasing pressure to reduce the electricity consumption of their optical networks.

The electricity consumed by the optical network units (ONUs) installed in customer homes is particularly critical, since their sheer number means that they account for a very large chunk — according to one estimate, over 50% — of the electricity consumed by a whole network. It is for this reason that NTT is focusing on reducing the amount of electricity consumed by ONUs through integration on single chips and reducing the number of parts they contain. In addition to such hardware design measures, the adaptive power saving control technology being developed by NTT Access Network Service Systems Laboratories is also attracting attention as a methodology-based solution.

This technology regulates the amount of electricity consumed according to the amount of traffic between the ONUs in each home and optical line terminals (OLTs) on the exchange side. For example, when a customer is not using the service, these devices now slip into a sleep mode, reducing electricity consumption to the bare minimum. The technology also adjusts transmission speeds between OLTs and ONUs according to usage status so as to save electricity.



● Green of ICT

Tokyo No.5 Data Center, one of Japan's greenest data centers



As the demand for data centers grows, so does the need for them to be energy-efficient and capable of withstanding disasters. NTT Communications is focusing on the deployment of data centers boasting advanced green ICT features that put them in the top league worldwide.

In April 2011, the company completed and launched operations at its Tokyo No.5 Data Center, a seismically isolated structure capable of withstanding quakes on the scale of the Great East Japan Earthquake and Great Hanshin-Awaji (Kobe) Earthquake. Equipped with energy-efficient electrical equipment and an advanced airflow management system that reduces electricity consumption by up to 35%, Tokyo No.5 boasts a power usage effectiveness (PUE) of under 1.45, making it one of Japan's greenest data centers. This performance won recognition in June 2011 when the ASP-SaaS-Cloud Consortium awarded Tokyo No.5 the Grand Prix in the data center category of its 5th ASP-SaaS-Cloud Awards.

Overseas too, NTT Communications is contributing to society by deploying data centers that reflect its unswerving focus on comprehensive eco-friendly design and operation.

Deploying next-generation green base stations that use renewable energy to reduce power consumption



Responding to the growing demand for energy-efficient telecommunications infrastructure and stronger disaster countermeasures following the Great East Japan Earthquake, NTT DOCOMO has started to deploy next-generation green base stations in line with its SMART for GREEN 2020 environmental vision. Green base stations are designed to consume less commercial electricity from power utilities by being fitted with



Next-generation green base station

devices such as solar panels, wind turbines, fuel cells and DC green power controllers. They are also equipped with lithium-ion rechargeable batteries that store surplus electricity that can be

used during power consumption peaks or power outages caused by disasters.

NTT DOCOMO plans to deploy 10 next-generation green base stations by the spring of 2013, and is also constructing a system for visualizing power supply and demand in its base stations throughout Japan, and conducting R&D aimed at creating its own smart grid for sharing power among multiple green base stations.

Full operation of large-scale solar power generation testing system



Under a project commissioned by the New Energy and Industrial Technology Development Organization (NEDO), NTT FACILITIES conducted research from fiscal 2007 to fiscal 2011 aimed at verifying grid stabilization of large-scale solar power generation systems.

The project involved the building of a large-scale system with a generation capacity of 1.84 MW in Hokuto City, Yamanashi Prefecture, a location blessed with more sunlight on average than anywhere else in Japan, to develop grid stabilization technologies for eliminating any adverse impacts on a grid of the fluctuating output inherent to solar power systems, and to ascertain the power generation capabilities of different types of photovoltaic cells.

In fiscal 2012, NTT FACILITIES completed a report presenting the findings of its five years of research, together with STEP-PV (Simulation Tools for Estimating system output Power of a large-scale PV plant) by enabling estimation of power output and environmental contribution. These and earlier findings have been published on NEDO's website to contribute to the smooth deployment of solar power generation systems.

The Hokuto facility is currently being used by the city of Hokuto as an environmental education site that attracts approximately 5,000 visitors per year.



Photo: Hokuto City



● Green of ICT

Energy-efficient fresh air-cooled data center (test facility): Reducing costs and environmental footprint through using only fresh air for cooling



Responding to growing demands to reduce data center costs and energy consumption, NTT COMWARE in November 2011 started testing an energy-efficient fresh air-cooled data center that delivers cost savings and has a smaller environmental footprint than conventional data centers.

The test data center takes in fresh air and expels air heated by the operation of ICT equipment, eliminating the need for cooling systems and reducing the environmental footprint by cutting air conditioning-related electricity consumption by 20% compared with previous NTT COMWARE data centers. The use also of DC-driven ICT equipment to minimize AC/DC power conversion losses and other measures enabled the achievement of a PUE* of less than 1.1 during the six-week testing period.

NTT COMWARE is planning to carry out year-round testing with a view to the eventual use of such data centers for its SmartCloud enterprise cloud services.

***Power usage effectiveness**

A measure of how efficiently a computer data center uses its power. PUE is calculated by dividing the total power consumption of a data center by the power consumption of the computing equipment it houses. The closer PUE is to 1, the higher is the center's efficiency.

NTT COMWARE's fully fresh air-cooled data center

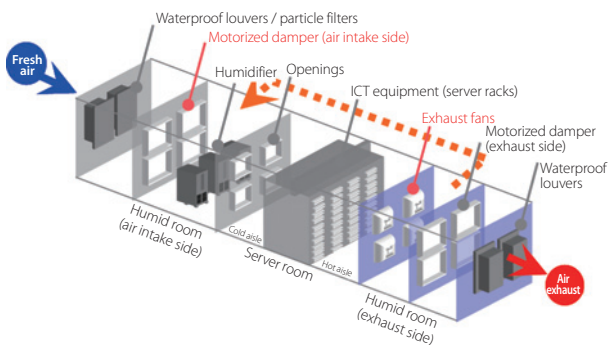

Exhaust fans for expelling heat generated by ICT equipment



Motorized damper (air intake side) for drawing in fresh air

Improving building energy use through EMC energy-saving proposals



In addition to fitting buildings with energy-efficient equipment when constructing them, the everyday management of buildings once they are in use can also make a big difference to their energy efficiency. This is why the NTT Urban Development Group is taking measures to reduce energy consumption and CO₂ emissions by improving the energy management of its buildings based on detailed status monitoring.

At the core of such efforts are building and energy management systems (BEMS) that enable more efficient energy use through managing the operation of a building's fittings and other equipment. The NTT Urban Development Group established an Energy Management Center (EMC) in 2005 to analyze BEMS measurements and formulate measures for system control optimization, and EMC has since provided both the Group and its tenants with suggestions for efficient energy use, as well as fine-tuning BEMS to best match building load.

EMC has developed a methodology based on the results of its analysis, and has since 2008 regularly published papers on its findings in the Journal of the Society of Heating, Air-Conditioning and Sanitary Engineers of Japan. The measures developed as a result of these efforts are also being applied to other buildings to help save energy, and reduce CO₂ emissions and energy costs. The NTT Urban Development Group, which owns over 100 buildings nationwide, has so far deployed BEMS in 12 large-scale properties.

Also, it is becoming increasingly important for building owners to enlist the cooperation of tenants to supplement their own efforts to achieve further energy savings and CO₂ emission reductions. The NTT Urban Development Group in fiscal 2011 accordingly started to hold tenant liaison meetings for large-scale properties coming under Tokyo Metropolitan Government's Environment Protection Ordinance.



Tenant liaison meeting



Green by ICT

Operation of Environmental Solution Certification System



Utilization of ICT services can reduce the environmental footprint of society as a whole. To help communicate ICT's environmental contribution to its customers and drive its own environmental endeavors, the NTT Group established and launched operation of its own Environmental Solution Certification System in fiscal 2010.

Under this system, ICT solutions of group companies that reduce environmental impacts to a certain extent will be certified as eco-friendly solutions and given the system's label. To qualify for Environmental Solution Certification, a solution must demonstrate an environmental contribution equivalent to CO₂ emissions reductions of more than 15% when subjected to quantitative evaluation.

We introduce certified solutions on the Environmental Solution Certification System section of our official website's NTT Group Environmental Protection Activities web page, along with details of our evaluation methods. In fiscal 2012, seven solutions received Environmental Solution Certification, bringing the current total of certified solutions to 19, following the four solutions certified in fiscal 2010, and eight in fiscal 2011.

Moving forward, we will seek to identify any issues in the operation of the system so far, and to further boost the number of certified solutions.



Environmental Solution Label

Promoting the deployment and spread of high voltage DC (HVDC) power supply technologies



Switching from conventional alternating current (AC) power supply to high voltage direct current (HVDC) power supply is seen as a promising way to reduce power consumption in ICT fields.

HVDC power supply reduces the number of conversion stages from AC to DC power, thus reducing the losses involved in such power conversion, and enabling a reduction of about 15% in power consumption compared with AC power supply. It also helps to boost reliability by reducing failure rates, since it can be

supplied to devices directly from batteries.

Because of these benefits, the NTT Group is making groupwide efforts to promote the deployment and spread of HVDC power supply systems, and as one such initiative, has been conducting research in the use of such systems to create greener data centers.

To boost the energy efficiency of data centers, we have conducted field tests at NTT DATA's Mitaka Building, participated in a Ministry of Internal Affairs and Communications-funded research project, and tested experimental equipment at our laboratories and NTT FACILITIES, and have found that savings of 15-18% are feasible. The results of the Ministry-funded research will be used as core data by the Ministry in a proposal to be submitted as Japan's contribution to an international standardization organization with the aim of winning worldwide recognition for Japanese power supply systems and expanding the global market.

Based on the above achievements, in fiscal 2012, group companies and research laboratories began installing HVDC systems, and NTT FACILITIES started to offer them as products. With the both the European Telecommunications Standards Institute (ETSI) and ITU-T standardizing 260-400 V as the voltage range for HVDC system interfaces, the conditions are also now in place for the global uptake of HVDC power supply technology.

High voltage DC power supply system

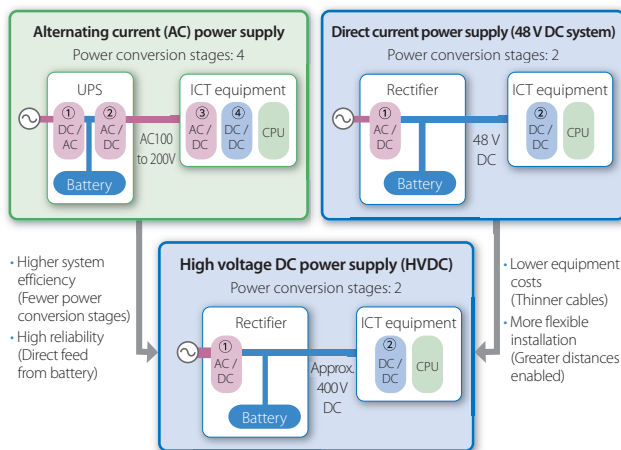



Green by ICT

Developing technology for optimizing data center energy supply and demand



Air-conditioning equipment accounts for about 30% of data center electricity consumption. Making air-conditioning equipment more energy-efficient is accordingly a major aspect of reducing the environmental footprint of data centers.

NTT Energy and Environment Systems Laboratories (NTT EESL) is developing data center energy management systems (DEMS) for optimizing data center energy supply and demand by enabling centralized management and sophisticated cooperative control of server and other ICT equipment load and air conditioning equipment operation status.

In joint research with NTT FACILITIES carried out in fiscal 2012, NTT EESL used a DEMS to achieve power savings of over 18% through the cooperative control of multiple air-conditioning units. NTT is working on the drafting of an ITU-T recommendation for DEMS, and is examining the effectiveness of DEMS in multi-vendor environments and how to best balance reliability and safety with efficiency, with the aim of bringing out a commercial DEMS by the end of 2014.

Data center energy optimization

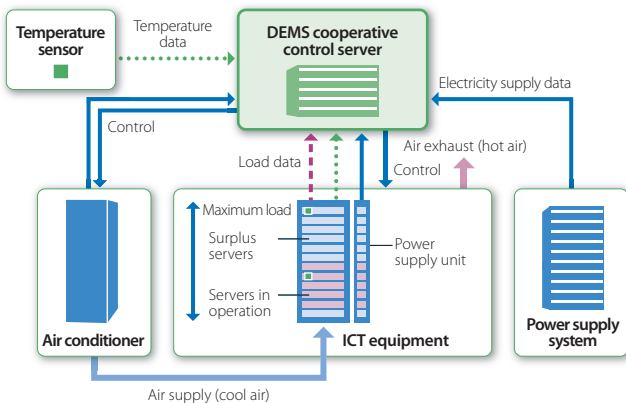

Reducing GHG emissions through automated meter reading and centralized monitoring systems



NTT TELECON, an NTT East Group company, has since the 1980s offered automated meter reading and centralized monitoring systems for the automated reading of gas, water and electricity meters through telephone lines and the monitoring and control of meters and other equipment. These systems are currently used in about 3 million households throughout Japan, mainly for LPG supply purposes.

These systems enable gas, water and electricity suppliers to automate meter reading and streamline such tasks as gas cylinder delivery, thus reducing the consumption of fuel required for meter reading and delivery vehicles, and consequently GHG emissions.

NTT TELECON has also used the Ministry of the Environment's Offset Credit (J-VER) scheme* to create a mechanism for rewarding customers who use these systems by enabling them to exchange GHG emission reductions for offset credits that have monetary value. This was the first J-VER project in Japan to use ICT. Launched in 2010 by NTT TELECON together with 14 domestic LPG suppliers, the project was credited with emission reductions of 7 t-CO₂ by the Offset Credit (J-VER) Certification and Steering Committee in May 2012.

NTT TELECON will continue its efforts to contribute to the creation of a low carbon society by promoting the further deployment of automated meter reading and centralized monitoring systems and providing new services that employ the same kind of technologies.

***Offset Credit (J-VER) scheme**

A scheme for certifying GHG emission reductions and absorption attributable to projects carried out in Japan as offset credits (J-VER)

Reducing GHG emissions through deployment of a system for automated meter reading and centralized monitoring

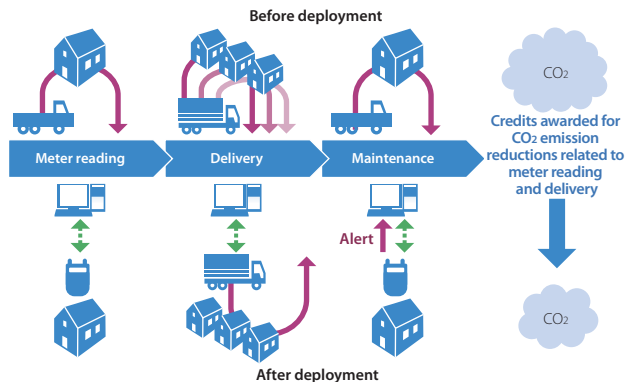



● Green by ICT

Launch of FLET'S Miruene service for visualizing household electricity consumption and supply



With the growing need for households as well as businesses to implement longer-term and more effective measures to save electricity, systems for visualizing electricity consumption are generating a lot of interest.

NTT East has since January 2012 been offering its FLET'S Miruene service for household electricity visualization to users of its FLET'S HIKARI service. This was first offered from July 2011 as a trial service named NTT East Electricity Visualization Service. Subscribers to the trial service were so satisfied, with high numbers wanting to continue using it, that NTT East decided to offer it as a full-fledged service.

Costing just 420 yen per month, including rental of necessary devices, FLET'S Miruene visualizes both household electricity consumption and electricity supply data provided by power utilities, and also features a diversity of functions for helping subscribers to save electricity and reduce CO₂ emissions, including eco-advice display/readout, setting of energy saving targets and display of rankings.

With the need to save electricity growing constantly, NTT East will continue to strongly support household electricity saving efforts through providing FLET'S Miruene as a very affordable and easily deployable service.

A FLET'S Miruene pack that includes all necessary equipment was also certified for subsidy under a Ministry of Economy, Trade and Industry 2011 subsidy program to promote the deployment of home energy management systems.

FLET'S Miruene service

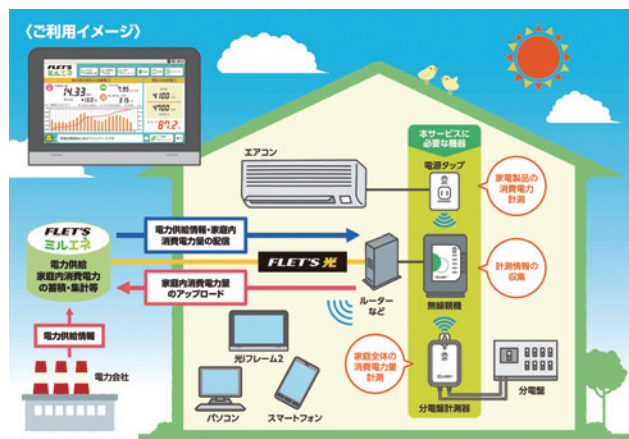

Testing a wind-powered container data center



Increasingly high density servers and the heat generated by rack upon server rack is driving up data center power consumption and creating an urgent need for means of curbing that consumption. Also, with the growth of cloud computing, there is increasing demand for data centers to be distributed in different geographical locations to ensure business continuity in the event of disasters. Container data centers that package power supply and air conditioning units along with servers in general-purpose containers are attracting attention as a means of addressing these needs.

In January 2012, NTT FACILITIES started testing what will be Japan's first wind-powered container data center. Enlisting the cooperation of Aomori Prefecture, NTT FACILITIES built a testing facility in the village of Rokkasho for a trial that will continue up to March 2013.

The first of the trial's main goals is to test technology for linking wind power generation with high voltage DC (HVDC) power supply. Wind power holds out promise as a source of renewable energy, but output fluctuates according to weather conditions, and needs to be stabilized in order to be usable as a data center power source. NTT FACILITIES is accordingly testing a combination of an HVDC power supply system that it started selling in November 2011 with a wind turbine to consider efficient and stable system design and develop operational expertise.

The second goal is to investigate operational technology related to direct fresh air cooling. NTT FACILITIES will evaluate year-round data center operation using direct fresh air cooling that takes advantage of Aomori Prefecture's cool climate.

The company plans to put the technological outcomes and expertise gained from the trial to use in providing eco-friendly data center construction solutions that make maximum use of renewable energy.



The container data center at the test site



● Green by ICT

Strengthening GreenITy Building® and other eco-friendly urban design initiatives



NTT FACILITIES has integrated its uniquely systemized component technologies for safety, reliability, energy efficiency, flexibility and the environment to develop long-life, low impact GreenITy Buildings.

Since the Great East Japan Earthquake, thinking on building safety and energy conservation has changed significantly. NTT FACILITIES for its part will endeavor to contribute to the creation of safe, low impact communities through the flexible combination of its GreenITy Buildings with eco-offices based on its Live-Link Design¹ office concept and smart buildings in which ICT is used to integrate energy-related data and optimize energy usage.

In fiscal 2011, NTT FACILITIES established its Environmental Architecture Award to pay recognition to particularly outstanding environmental initiatives implemented by NTT Group companies nationwide. Fiscal 2012's winner was the NTT East Training Center No.5 Building, a CASBEE S-rated² building equipped with a well-balanced range of environmental technologies, including cost aspects.

NTT FACILITIES has since October 2010 also been working on the conversion of Granpark Tower, the building that houses its head office, into a smart building. In addition to deploying BEMS³ and BAS⁴, the company is utilizing energy visualization system measurement data analysis and user work style diagnosis to investigate energy-saving performance and intellectual productivity trends.

It also installed a model eco-office on the 24th floor of Granpark Tower where its head office is located to conduct a year-long trial on eco-office implementation, and achieved considerable reductions in both electricity consumption and costs, including cutting power consumed by lighting by 70% and paper consumption by 43%. These achievements enabled NTT FACILITIES to earn LEED certification⁵ for the office. This was the first initiative involving the improvement of an existing building in Japan to earn LEED certification.

Moving forward, NTT FACILITIES plans to further build up its expertise in the construction of buildings that enable energy management optimization both by investigating the effectiveness of cases implemented up to now, and by actively installing the latest environmental technology, including systems for controlling supply and demand of electricity and heat.

1. Live-Link Design

A concept proposed by NTT FACILITIES for creating workspaces that deliver enduring value to customers by enabling their people to make the most of their talents and improve their productivity

2. CASBEE S

CASBEE, which stands for "Comprehensive Assessment System for Built Environment Efficiency", is an assessment system used by the Institute for Building Environment and Energy Conservation (IBEC) under the supervision of the Ministry of Land, Infrastructure, Transport and Tourism for rating buildings on a scale of five ranks from C (inferior) to S (outstanding).

3. BEMS: Building Energy Management System

A system for reducing the energy consumption of a building by monitoring and controlling building facilities and equipment

4. BAS (Building Automation System)

A system for monitoring and controlling air conditioning, lighting, transformers, disaster response, security, elevators, car parks and other facilities

5. LEED certification

LEED stands for "Leadership in Energy & Environmental Design", a US government system for rating green building design, construction, operations and maintenance. The model office received a Silver rating, the third of four ranks, in the category of Commercial Interiors, one of seven categories.



LEED certification

The 'LEED® Certification Mark' is a registered trademark owned by the U.S. Green Building Council® and is used with permission.



Model office



● Green by ICT

Reducing power consumption and CO₂ emissions by using heat-dissipating paint to boost air conditioning heat exchanger efficiency



NTT Intelligent Planning and Development (NTT IPD), a company that develops ICT-based office solutions, released an air conditioning electricity conservation solution in November 2011 that makes use of NeOCOAT, a heat-dissipating paint, to boost air conditioning heat exchanger efficiency and greatly reduce electricity consumption, reducing CO₂ emissions too as a result.

NeOCOAT is a next-generation eco-paint which dissipates heat by converting thermal energy to kinetic energy using heat exchange molecules. Since they react to heat, the heat exchange molecules continue to work to suppress temperature even if the painted surface is dirty. And since the heat exchange molecules in NeOCOAT stop reacting to heat below 25°C, the paint does not burden room heating in winter when outside temperatures drop. Moreover, unlike commonly used heat-shielding paints, NeOCOAT does not reflect sunlight and so can help to mitigate urban heat island effects.

Applying NeOCOAT to air conditioner external units and the floors around them can suppress their temperature and thus help to maintain their heat exchange efficiency. A two-week field trial conducted in September 2011 showed a temperature difference of 9°C between an external unit painted with NeOCOAT and an unpainted unit.

With the growing demands for electricity conservation, NTT IPD aims to contribute to energy conservation across society through offering heat-dissipating paint as an easy means of saving electricity.

● Green with Team NTT

Greening the rooftops of buildings throughout Japan



Rooftop greening not only adds to the scenery, but also delivers a range of environmental benefits, including purifying air through absorbing CO₂ and releasing oxygen. Vegetation can also help to mitigate temperature increase and heat island effects through plant transpiration, and reduce air conditioning power consumption through its insulating effect, keeping temperatures down over the whole building.

Aware of these benefits, the NTT Group is actively greening the rooftops of group company office buildings, data centers, telecommunications buildings and other facilities with a diversity of plants including sweet potato, bitter melon, cucumber, morning glory, loofah, bell pepper, pansy, rape, azalea, Japanese zelkova and lawn grass.

For example, at its Urbannet Mita Building in Tokyo's Minato Ward, NTT Urban Development is growing sweet potatoes using an aero-hydroponic system*, and bitter gourds, grapes and other plants as wall greenery using special bags of soil mixed with fertilizer. It also started beekeeping in fiscal 2011 to test the effectiveness of natural pollination by honeybees.

NTT West Kansai Regional Headquarters has also planted colorful flower beds at its five Kyoto buildings to match the surrounding scenery, and grows bitter gourds that it harvests to serve at social events etc.

***Aero-hydroponic system**

Liquid fertilizer is circulated through the cultivation unit.



Sweet potato plants grown using an aero-hydroponic system



● Green of ICT

Targets and results



In the waste materials targets coming under “Implementing closed loop recycling”, our target for final disposal rate for all waste materials was 2% or less, and for decommissioned telecommunications equipment, our target was the continued achievement of zero emissions*. Our final disposal rate for all waste materials for fiscal 2012 decreased by approximately 0.49% from the previous year to 1.75%. Our final disposal rate for decommissioned communications equipment was 0.04%, and as such, we achieved zero emissions for the eighth consecutive year.

***Zero emissions**

A concept proposed by the United Nations University that calls for reusing all waste materials and by-products from industrial activity as resource inputs for other types of production in order to eliminate waste on a lifecycle basis. The NTT Group considers a final disposal rate of 1% or less to satisfy zero emissions conditions.

Final disposal rate

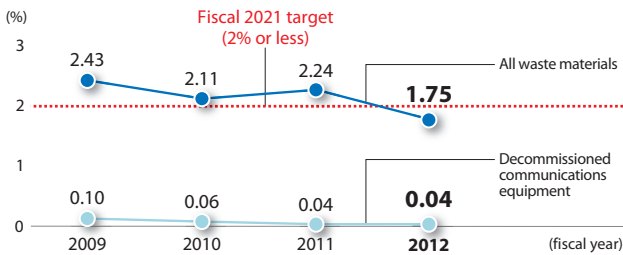

Our target for reducing paper consumption was a reduction of 30% or more by fiscal 2021 compared with fiscal 2009 (to a total of 58,000 tons or less). Our total paper consumption for fiscal 2012 was 66,000 tons, a year-on-year decrease of 6,000 tons.

Total paper consumption

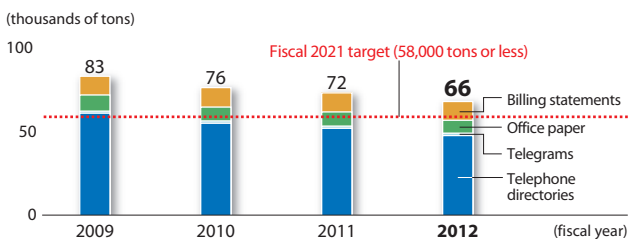

Reusing and recycling waste from communications equipment installation/decommissioning



The NTT Group owns a variety of communications equipment including telephone poles, switching equipment and communications cables. Such equipment needs to be decommissioned and disposed of when it reaches the end of its service life or is replaced during system upgrades for new services and so forth. We promote the reuse and recycling of such decommissioned communications equipment within the Group, and recycle whenever possible, for example recycling discarded concrete blocks as road building material.



Cable waste



Concrete waste



● Green of ICT

Recycling mobile phones to make use of valuable resources



Containing gold, silver, copper, palladium and other metals, mobile phones could be regarded as a valuable recycling resource in Japan with its paucity of mineral resources.

NTT DOCOMO has collected and recycled used mobile phones since 1998. In 2001, it partnered with the Telecommunications Carriers Association to build the Mobile Recycle Network to collect mobile handsets irrespective of carrier, and collects used phones from retailers as well as docomo Shops. In fiscal 2012 it collected 3.72 million handsets, making for a cumulative total of 80.36 million. Collected phones are subjected to data deletion and crushing in the presence of the customer to protect personal information.

DOCOMO does its utmost to advertise the importance of phone recycling, displaying used phone collection stickers in docomo Shops and promoting collection at events to further enhance these efforts. It is also participating in the Mobile Phone Recycling Promotion Council established in July 2011 under the coordination of the Ministry of Economy, Trade and Industry, Ministry of Internal Affairs and Communications, and Ministry of the Environment, and working with other corporate participants to get the phone recycling message out to the public and drive the Council's collection promotion activities.



Sticker promoting the collection of used phones

● Green by ICT

Research on techniques for analyzing telecommunications business resource utilization



Quantitatively monitoring and analyzing resource flow (input, accumulation, output), and using the information gained as basic data is an important aspect of reducing resource consumption and the waste generated by business activities. However, unlike manufacturing industries, which procure raw materials directly and can thus easily monitor resource input, non-manufacturing industries such as telecommunications, which procure ready-made equipment rather than raw materials, are unable to monitor resource input on a raw material basis.

NTT Energy and Environment Systems Laboratories (NTT EESL) has accordingly been studying resource utilization by telecommunications companies. NTT EESL is currently researching both top-down and bottom-up techniques for analyzing resource input, using various management data for the former, and data on resources contained in procured items for the latter. The results of its calculations for the top-down approach are featured in NTT East and NTT West's CSR reports.



● Green by ICT

Provision of a returnable transport item management system as an SaaS service



NTT LOGISCO has developed ECO-PRA¹, a management system for keeping track of returnable transport items (RTI) such as pallets, containers and drums, and started offering it in January 2011 as an SaaS² service.

ECO-PRA can help to improve RTI circulation and prevent uneven distribution and shipment delays by enabling the real-time sharing of information on individual RTI location, movement history, inventory, etc. between multiple logistics sites, and as such, supporting the practice of the 5Rs of Reduce, Reuse, Repair, Return and Recycle. Since ECO-PRA is offered as an SaaS service, it is low cost, quickly deployable and very scalable, enabling speedy and flexible response to expansion of usage area or business volume.

ECO-PRA was originally developed as a group environmental activity to manage plastic drums for telephone pole support cables, and by fiscal 2012 had been introduced to four logistics centers in Nagoya, Sakai, Kanazawa and Saitama, managing a total of 6,720 drums. It was deployed in all NTT Group logistics centers except Okinawa by September 2012, and was already being used to manage optical cable plastic drums by July 2012.

Going forward, NTT LOGISCO plans to make ECO-PRA even easier to use by engineering its integration with warehouse management systems and logistics information solutions that make use of smartphones and other mobile terminals.

1. ECO-PRA:

Ecological and Economical Platform for RTI Application

2. SaaS:

Software as a Service — the provision of software as a service over the Internet

Confidential document collection service that leverages ICT



NTT LOGISCO is helping businesses to dispose of large volumes of confidential documents that they no longer have need of. It developed its own SS-BOX secure disposal bins and recycling system for the safe and simple collection and processing of such documents, and by fiscal 2011 had installed a total of about 9,000 of these bins in companies throughout Japan.

It empties the bins regularly, shredding the collected documents for recycling as toilet paper or cushioning material for packaging. In fiscal 2012, it collected and recycled 11,713 tons of confidential documents using this system.

From December 2010, it started to offer the iSS-BOX, a high function version fitted with an NTT DOCOMO FOMA transmission module, to drive the further spread of the service. The iSS-BOX automatically notifies NTT LOGISCO of the volume of documents inserted, reducing collection costs by enabling collection at just the right time, and relieving the customer of the need to notify NTT LOGISCO. Over 400 of these new bins had been installed by the end of 2011.

This confidential document collection service was approved under the NTT Group's Environmental Solution Certification System in July 2011.



● Green of ICT

Addressing environmental risks



The key environmental impacts of the NTT Science and Core Technology Laboratory Group's main facility, the NTT Atsugi Research and Development Center, include the use of chemicals, generation of wastewater, gas emissions and waste products, and consumption of electricity by the air-conditioning systems of the clean rooms that it uses for research. NTT invests systematically in plant and equipment to prevent contamination from such impacts.

To monitor and assess environmental impacts, NTT SCTLG also conducts regular environmental surveys of air, rainwater/groundwater, odors, soil, noise and vibration, as well as round-the-clock monitoring of water quality and other items. It also endeavors to prevent contamination by setting voluntary targets that are more rigorous than legally mandated targets. In the air quality survey that it conducted in fiscal 2012, all results were within both mandatory and voluntary limits. In fiscal 2013, it will conduct water quality and noise/vibration surveys.



Air quality survey

Leveraging overhead cable stringing technology to help protect endangered species



NTT East Yamanashi Branch Group and NTT East's Technology Cooperation Center have since April 2009 been supporting the animal pathway creation efforts of the Animal Pathway Research Society (APRS) in Hokuto City, Yamanashi Prefecture. APRS is made up of Kiyosato Educational Experiment Project (KEEP) Dormouse Museum and several companies in addition to NTT East, including Taisei Corporation and Shimizu Corporation.

Animal pathways are bridges or tunnels connecting wildlife habitat that has been divided by roads to help protect populations of endangered species such as the Japanese dormouse (about 8 cm long) that use tree branches as paths.

Creating and maintaining such pathways for small tree-dwelling animals invariably involves equipment and technology for stringing overhead cables. The Yamanashi Branch is leveraging its cable stringing expertise to support these efforts by providing boom lift trucks and veteran operators for such work.

This initiative was recognized in May 2010 with a Minister of the Environment award in the Keidanren Committee on Nature Conservation's 1st Contest for Corporate Activities on Biodiversity.

The NTT Group is currently maintaining animal pathways in the city of Hokuto, and in fiscal 2012, replaced a main cable that had rusted. The replaced cable supports NTT communications cables, and so the job was one that made the most of NTT's communications technology for connecting people.

In October 2011, another animal pathway was established in the Nasu Heisei-no-Mori Forest in Tochigi Prefecture as the first pathway towards taking this initiative nationwide. There are plans for additional pathways in Nagoya and Chino in Nagano Prefecture. NTT will continue to help protect tree-dwelling animals through supporting the spread of animal pathways.



Animal pathway improvement



Green of ICT

Designing submarine cable laying routes to minimize impact on coral reefs



NTT Communications endeavors to minimize impacts on the marine natural environment of shallow coastal areas when planning routes for the laying of submarine cables.

For example, we endeavor to protect coral reefs and the creatures living within and around them by carrying out detailed assessments in areas of coral to develop plans that enable us to avoid the coral colonies as we lay cables. In the Inland Sea, where the majority of the marine area is designated as a national park, we work with the relevant government agencies and local authorities to develop careful plans before laying cables.

Also, when cable-laying ships raise their anchors, there is a risk of marine organisms being brought up with anchors and transplanted to other areas where they could disrupt the local ecosystem. To prevent this from happening, NTT Communications ensures that anchors and anchor pockets are cleaned meticulously.

Biodiversity risk analysis and creation of a relationship map



In line with the NTT Group's basic policy, NTT FACILITIES sees the preservation of biodiversity as the preservation both of biodiversity and the benefits to be gained from biodiversity.

To ascertain the impact of its main business activities on the preservation of biodiversity, in fiscal 2011 NTT FACILITIES analyzed biodiversity-related risks, identified factors, and organized priorities. It analyzed the impacts not only of its own activities, but also those of its suppliers, users and other indirect impacts over complete lifecycles, and visualized the results as a biodiversity preservation relationship map that it uses in its GreenITy Building projects and other business activities (see illustration below).

It is currently drawing up an action plan based on the results of this analysis.

Map of the relationship between GreenITy Building projects and biodiversity

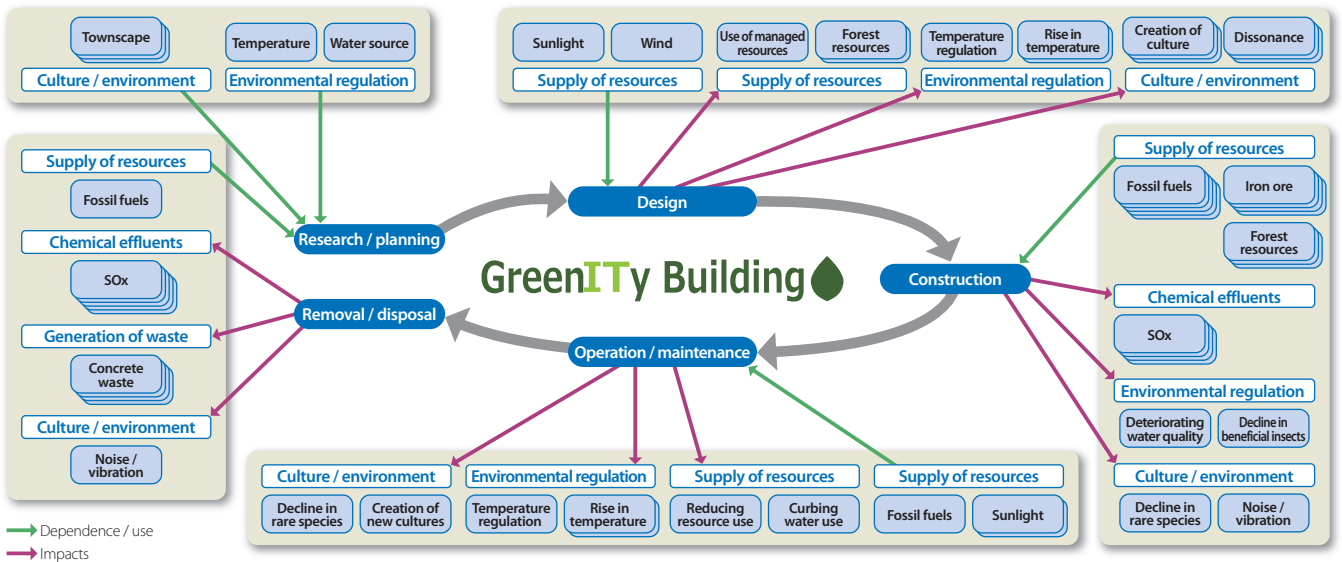

Conforming to Japan Business Initiative for Biodiversity (JBIB)'s Business and Biodiversity Interrelationship Map
 • This is an abridged map showing only major ecosystem services.



● Green by ICT

Supporting environmental protection through the goo Green Label search portal



NTT Resonant, an NTT Communications Group company, posts various local and international news items about the environment on *Kankyo goo*, a dedicated environmental section launched in 1999 on its goo portal site. *Kankyo goo* content includes interviews with leaders of companies noted for their efforts for the environment, an environmental education section and a comprehensive glossary of environment-related keywords.

In August 2007, NTT Resonant launched the goo Green Label search portal for funding environmental protection activities through Internet usage. A part of the revenue generated from use of the portal is donated to NPOs and NGOs engaged in activities to protect the environment. By March 2012, a cumulative total of 43 million yen had been donated to 82 organizations.

The Great East Japan Earthquake of March 2011 prompted the selection of the National Land Afforestation Promotion Organization, a public service organization that is supporting the recovery of the disaster zone through reforestation and other projects, as the single recipient of the goo Green Label donation for fiscal 2012. The Director-General of the Forestry Agency presented NTT Resonant with a letter of appreciation for this donation, which amounted to 7 million yen, in December 2011.

Following the previous year, NTT Resonant also held *Ecokids 2011*, a web research and learning contest for third to sixth graders that involves using goo Green Label and other websites to learn about the current status of the global environment and think about the future. The contest attracted 1,217 entries from 99 schools nationwide, surpassing the previous year's total. Winning entries were announced at the Eco-Products Exhibition.



Kankyo goo screenshot



goo Green Label screenshot



One Million Clover Campaign screenshot



● Green with Team NTT

Organizing Operation Clean Environment cleanups nationwide as hands-on environmental education activities



NTT Group companies hold local community cleanups at their sites throughout Japan to raise the environmental awareness of their employees through participation in hands-on activities.

We have set a participation target of 100,000 people annually in this Operation Clean Environment initiative, and as a result of active campaigning, the number of participants is growing with every passing year. About 118,000 people participated in fiscal 2012, an increase of about 26,000 over the previous year.

The fiscal 2011 Mt. Fuji Cleanup, in which NTT Group companies covering various regions participated in as an activity symbolizing group cleanup efforts, was, in fiscal 2012, combined with Operation Clean Environment to be continued as a closely related activity.

To continue to develop Operation Clean Environment and achieve the annual target of 100,000 participants as well as share information on the status of the initiative, we plan to manage and monitor the cleanup activity records of major group companies as an environmental performance data item, and make this data available to group companies.



Local community cleanup

Implementing the 3/11 Recovery Forest Project as a hands-on environmental education activity



In March 2012, the NTT Group implemented the 3/11 Recovery Forest Project, a tree planting project organized as part of efforts to assist in the recovery of regions affected by the Great East Japan Earthquake.

The aim of the project was to restore the coastal forest shelterbelt of the Kujukuri Tonoshita area in Chiba Prefecture. The forest was destroyed by the 3/11 tsunami, which toppled many

trees and left many more to die from salt damage. With the cooperation of NPO Laboratory of Earth Conscious Life, 113 group employees, family members, former employees and others participated in the project, planting 1,260 black pine, Japanese pittosporum, Japanese spindle and other saplings on 1,200 m² of coastal land.

Forest shelterbelts not only help to mitigate tsunamis, strong winds and drifting sand, but also provide habitat for forest insects and help create rich fishing grounds, and so restoring the shelterbelt will also contribute to biodiversity. The NTT Group will continue to work with employees, their families and members of local communities on environmental conservation activities for the way they serve as opportunities to think about environmental issues.



Tree planting

Tree planting

Initiatives to protect forests and raise awareness of environmental issues



NTT COMWARE launched its Company Forest NTT COMWARE (Ome) initiative in fiscal 2009, and is working with its employees and their families, former employees and members of local communities on forest conservation activities.

In fiscal 2012, it carried out a number of activities, including brush clearing and tree planting, between May and October, with 110 people taking part.

It also continues to provide environmental leadership training aimed at equipping employees with practical forest conservation skills.



Environmental management

Current status of NTT Group's ISO 14001 certification acquisition

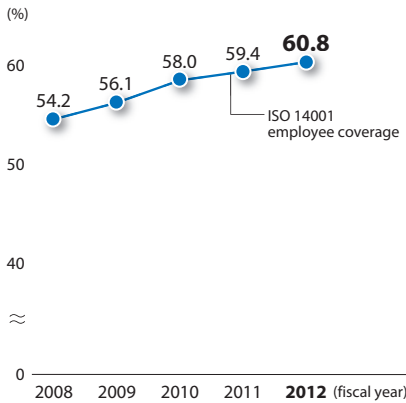

Creating a low carbon society

Greenhouse gas emissions other than CO₂ emissions (CO₂ emissions - equivalent)

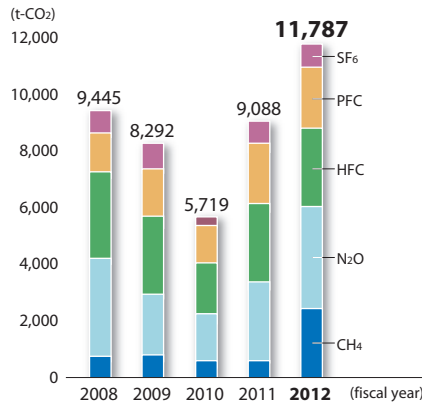

Electric power consumption

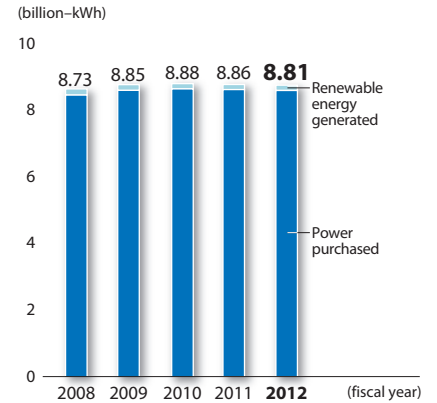

Creating a low carbon society

Clean energy generation

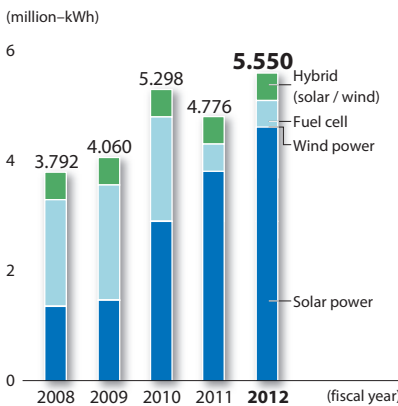

Number of clean energy generators

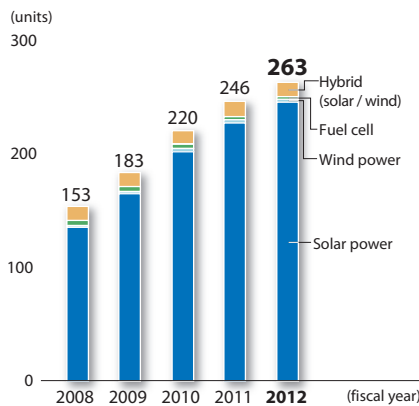

Number of low-emission company vehicles

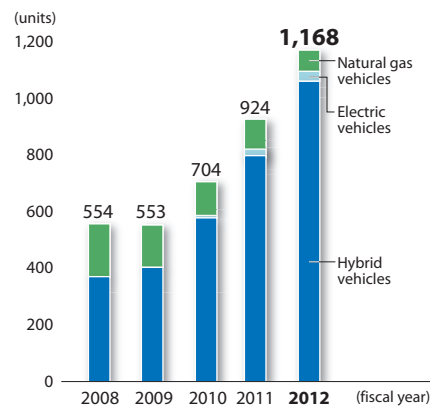

Creating a low carbon society

Fuel consumption by company vehicles

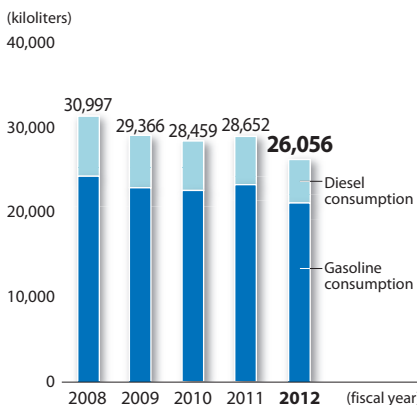

Implementing closed loop recycling

Waste output and final disposal waste

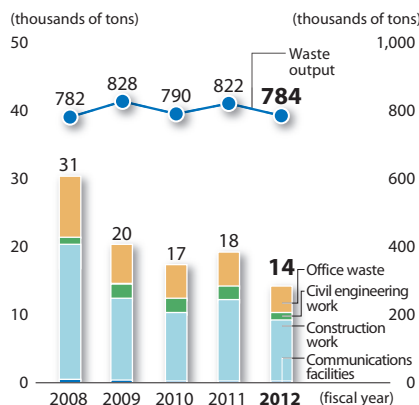

Medical waste

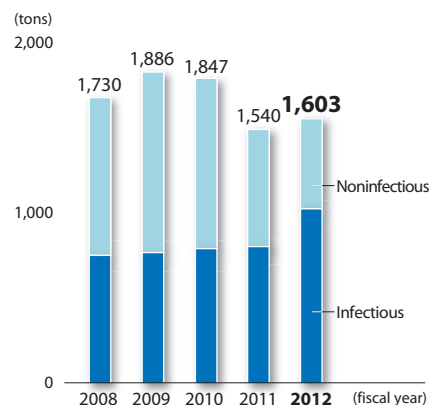



Implementing closed loop recycling

Virgin pulp consumption

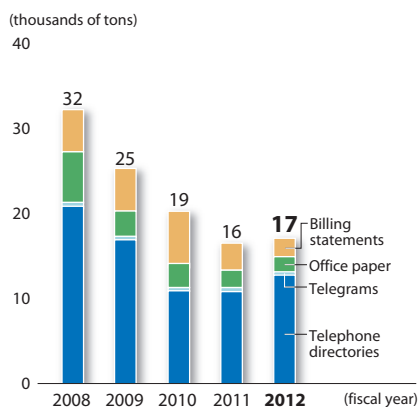

Paper consumption reductions from NTT Internet billing services

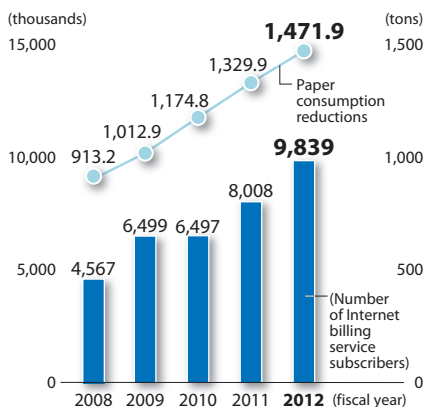

Number of recycling boxes installed and amount of confidential documents collected

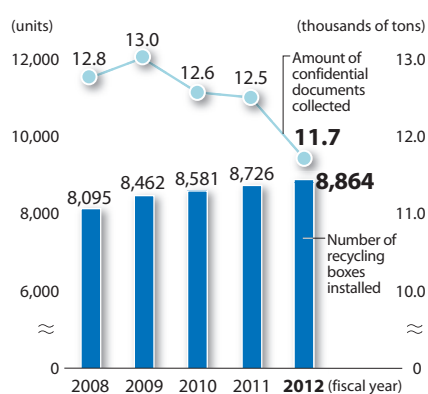

Conserving biodiversity

Participants in Operation Clean Environment

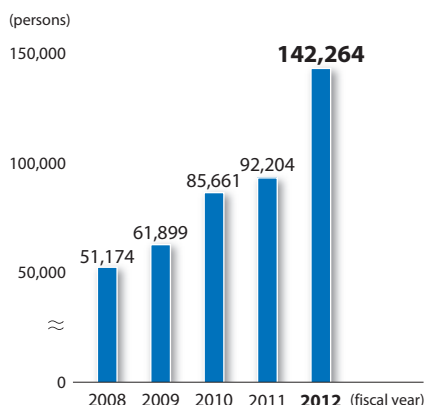

Other

Asbestos removed from NTT Group facilities

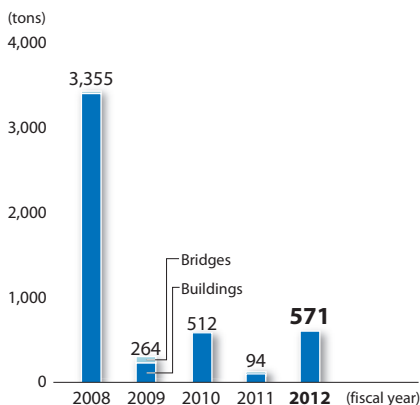

Amount of specified halon held for fire extinguishing equipment

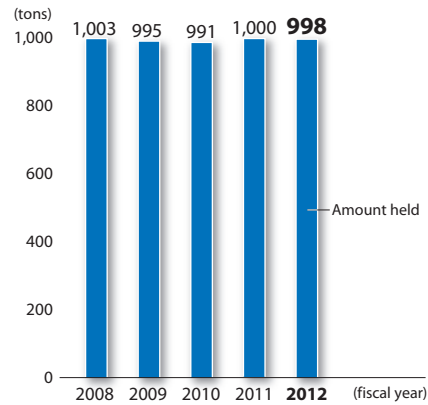

Other

Amount of specified chlorofluorocarbons used in air conditioning equipment

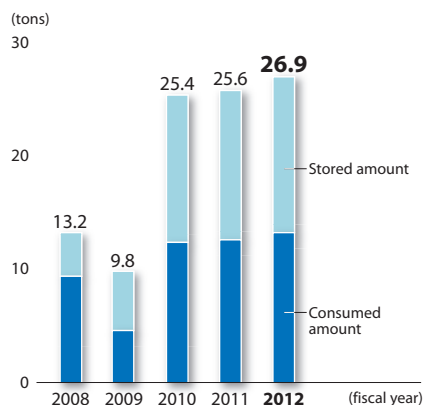

Number of centrifugal chillers (that use CFCs) and number of units removed

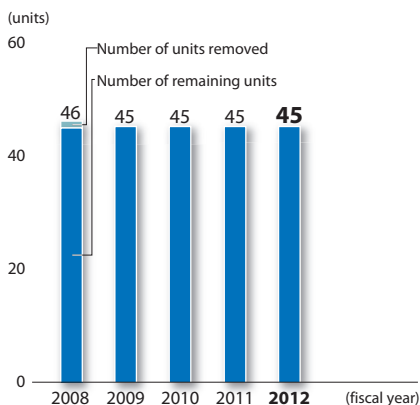

Safe and secure communication



Goal 1

Ensuring stable and reliable services as critical infrastructure

Goal 2

Ensuring information security

Goal 3

Creating a sound user environment

Goal 4

Customer satisfaction initiatives

We are committed to providing safe, reliable and disaster-resistant ICT services as vital infrastructure that enables people to connect with each other in any contingency, ensures information security, and protects and supports everyday life and society as a whole.

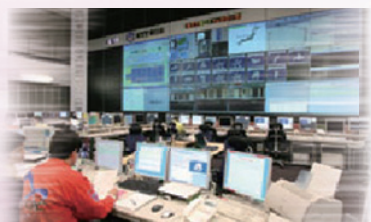



Managing and maintaining communications services

Maintaining a disaster-resistant communications infrastructure



Communications networks represent lifelines that are indispensable to the functioning of society, business activities and public safety. The NTT Group endeavors to build disaster-resistant communications infrastructure, and maintain and operate it in a way that ensures its proper functioning at all times.

For example, NTT East, NTT West, NTT Communications and NTT DOCOMO monitor their communications networks on a 24/365 basis from their operation centers. In the event of a failure caused by a disaster or some other contingency, they work to restore service by switching to standby equipment and other means through remote operations.

Also, with the spread in recent years of mobile phones, use of public telephones has declined, but public telephones still have a valuable role to play as a means of communication during disasters and other emergency situations, and as such, NTT East maintains about 58,000, and NTT West about 51,000 type 1 public telephones*.

*Type 1 public telephone

Installed to serve as the minimum means of communication at a density of one every 0.25 km² in urban areas, and one every 1 km² in other areas



Operation center

Developing a system for visualizing corrosion level to improve the reliability of outdoor communications equipment



Steel pipe telephone poles, metal fittings and other outdoor structural components are indispensable to the provision of communications services. This exposure to the outdoor environment tends to corrode or otherwise degrade the metals that are a key component of these structures, and efficient maintenance to prevent such degradation is of vital importance.

Since the main cause of metal corrosion is exposure to sea salt particles, NTT Energy and Environment Systems Laboratories (NTT EESL) has been developing a Sea Salt Corrosion Risk Visualization System that enables map-based monitoring of sea salt damage risks over a very wide area. NTT EESL completed development of

the system in fiscal 2012, and is now making the outcome of its efforts available to NTT Group companies.

Based on measurements taken throughout Japan, the Sea Salt Corrosion Risk Visualization System visualizes sea salt corrosion risks on maps using indicators such as sea salt particle quantity, corrosion speed, corrosion quantity and life expectancy. This is expected to boost our operational efficiency by facilitating the formulation of plans for maintaining vast quantities of equipment and replacing equipment in high-risk areas with components designed to withstand corrosion, as a result improving the reliability of our equipment and reducing our environmental footprint by extending its useful life.

Sea Salt Corrosion Risk Visualization System

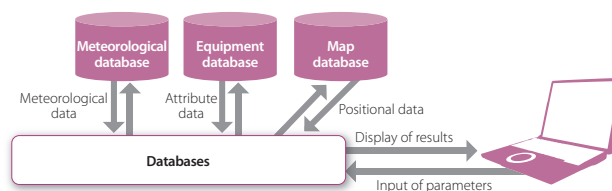

Combining domestic and overseas service centers to deliver one-stop service



NTT Communications provides a total 24/365 service to support the business growth of customers with global operations by providing stable, high quality ICT infrastructure irrespective of region, including establishing alternative trunk routes, duplicating or decentralizing telecommunications facilities, monitoring service status and processing error reports.

NTT Communications' domestic and global service centers were previously located on separate floors, but it brought them together on the same floor in fiscal 2011 and consolidated both sections into a single organization in fiscal 2012 to provide a one-stop service to customers using networks that combine both domestic and international lines. It also enabled even more seamless integration of domestic and overseas operations in fiscal 2012 by combining service manager duties for operations/quality management, improvement proposals and other tasks.

In the wake of the Great East Japan Earthquake, both domestic and global service centers worked with each other and with equipment sections and overseas subsidiaries, leveraging expertise gained from disaster drills and past earthquakes to promptly ascertain damage and implement workarounds.



● Disaster readiness

Communications network disaster preparedness based on three basic policies



1. Improving communications network reliability

The NTT Group is endeavoring to further enhance the reliability of its communications networks, and has learned many lessons from past disasters that it has applied to ensuring the continuity of communications services in the event of a disaster through such means as trunk line multi-routing and distributed location of important communications centers fitted with transit switches.

We also strive to secure and improve the ability of communications equipment housings, steel towers and other facilities to withstand disasters such as earthquakes, flooding and fire in accordance with predetermined design standards.

2. Securing critical communications

When a disaster strikes, the telephone system of the affected area is inundated with calls, causing network congestion. Under such conditions, we suppress ordinary phone traffic to secure critical communications services necessary to conduct emergency rescue and restoration operations and maintain public order, and to keep emergency number services such as 110, 119 and 118* going.

We also provide general customers with Disaster Emergency Message Dial (171), Disaster Message Board Service and Disaster Emergency Broadband Message Board (Web 171) as means of checking on the safety of relatives and friends in affected areas.

Furthermore, we make our public telephones available free of charge, provide specially installed public telephones, lend out satellite mobile phones and install free phone charging points at evacuation centers and other locations in affected areas to secure means of communication for disaster victims.

*Emergency number for maritime accidents and incidents. Calling 118 connects the caller to Japan Coast Guard to report accidents at sea, oil slicks, suspicious vessels and any other maritime contingency that requires help. The 118 service was launched in May 2000.

3. Prompt restoration of communications services

The NTT Group stations highly mobile disaster response equipment such as power supply vehicles, portable satellite equipment and mobile base station vehicles equipped with satellite links at locations throughout the country to aid in the prompt restoration of services and securing of critical communications in disaster stricken areas. If communications services have been disrupted by a disaster or other causes, this equipment is used to restore services as rapidly as possible.

In the event of a major disaster, a disaster management headquarters and other emergency structures are also immediately set up to implement service restoration operations. Depending on the scale of the disaster, a wide area support network encompassing group and other affiliated companies around the country is also created to assist in disaster response.



Power supply vehicle



Portable satellite equipment



Mobile base station vehicle equipped with satellite links



● Disaster readiness

New initiatives prompted by the Great East Japan Earthquake

■ **Equipping communications buildings with stronger disaster defenses**

In addition to the backup power sources that communications buildings are already equipped with, we are expanding our emergency fuel stores to guard against prolonged wide-area power outages, boosting our fleets of power supply vehicles and other operational resources, and strengthening our flood defenses in line with local government hazard maps.

■ **Trunk line triple-routing**

We are introducing triple routing and detour routes for trunk lines between important prefectural communications buildings to minimize the impact of active faults, tsunamis and other hazards, and further boost the reliability of our infrastructure.

■ **Building Information Stations to prepare for disasters**

We are working with convenience stores, local governments and other organizations to install Wi-Fi hotspots and emergency telephone lines to use as means of communication after disasters.

■ **“Wi-Fi Car” wireless IP communications vehicles and communications rescue vehicles**

These vehicles are equipped with wireless transmission equipment to provide stopgap Internet and telephone connections to evacuation centers and incapacitated critical facilities in the aftermath of earthquakes, tsunamis and other disasters.

■ **Use of large zone base stations**

To secure communications in high population areas, we have deployed new base stations throughout Japan that are capable of covering large areas in emergency situations.

■ **Provision of Disaster Voice Messaging Service**

We have developed a new packet communications SMS service for use during disasters and other times when phone connections are down that enables people to record and send voice messages, and notifies recipients by e-mail.

■ **Strengthening base station power outage countermeasures**

To secure communications at prefectural and municipal offices during power outages, we have fitted critical base stations throughout the country with generators or long-lasting batteries.



Wi-Fi Cars



Communications rescue vehicle

Developing lightning surge analysis technology to protect communications devices in ordinary homes from lightning



Optical lines that transmit light pulses rather than electrical signals are achieving increasingly widespread penetration among ordinary households, with NTT optical service subscribers now numbering close to 22 million, but terminal devices are nevertheless prone to lightning surges, and a great many such devices are knocked out by lightning each year.

NTT Energy and Environment Systems Laboratories (NTT EESL) is accordingly working on the development of lightning surge simulation and analysis technology to investigate where and to what extent overvoltage and overcurrent caused by such surges occur in household communications and power supply lines. As a result of its efforts to refine the technology, NTT EESL was by fiscal 2012 able to pinpoint the routes by which lightning surges penetrate terminal devices installed in subscriber homes, and has made considerable progress in elucidating the mechanisms by which terminals suffer lightning damage.

In June 2012, it used this technology to elucidate the technical requirements for curbing lightning damage to the power supply and communications line ports of terminal devices installed in subscriber homes. It also examined methods for satisfying these technical requirements and confirmed their feasibility.

NTT plans to start applying this lightning surge analysis technology to customer buildings, communications buildings and other facilities in fiscal 2014.



● Disaster readiness

Expanding use of the Area Mail Disaster Information Service



NTT DOCOMO sends out mass "Area Mail" notifications to mobile phones in areas where strong tremors of a seismic intensity of 4 and above are expected after a seismic wave with a maximum seismic intensity of just under 5 or above is detected at two or more earthquake detection points.

Area Mail uses a global standard technology called Cell Broadcast (CB) that is not affected by traffic load and enables the simultaneous delivery of messages to all subscriber mobile phones in a specific area without using mobile e-mail addresses.

To enable local authorities to make use of the same Area Mail mechanism to communicate information when struck by a disaster, NTT DOCOMO also provides Area Mail: Disaster/Evacuation Information for sending mass notifications of disaster/evacuation information to all mobile phones in a specific area. In July 2011, the Area Mail: Disaster/Evacuation Information service, which had up to then been provided to municipalities for 21,000 yen per month, was made free of charge as one of the disaster countermeasures adopted in the wake of the Great East Japan Earthquake.

The number of local authorities deploying Area Mail grew rapidly after the Great East Japan Earthquake, leaping from 49 at the end of 2010 to 72 within three months of the disaster. This number further increased from July, when the service became free, reaching 969 local authorities by the end of fiscal 2012.

From February 2012, tsunami warnings issued by the Japan Meteorological Agency were added to the information automatically distributed in Area Mail notifications.

Moving forward, NTT DOCOMO will strive to maintain and improve the stability and reliability of the Area Mail system and expand the number of Area Mail-compatible handsets to enable even more people to benefit from the safety and reassurance that this service provides.

Area Mail

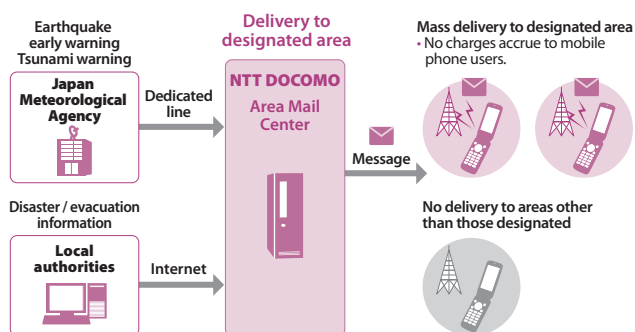

Installing large zone base stations for covering large areas in emergency situations



To secure communications in high population areas in the event of a large-scale disaster or power outage, NTT DOCOMO began to install large zone base stations in fiscal 2012. These base stations, which are exclusively for use during emergency situations, can cover a radius of 7 km, compared with the 1 km covered by ordinary base stations. NTT DOCOMO is installing them on highly quake-resistant buildings and steel towers, and is further ensuring their reliability through multi-routing and use of uninterruptible power supplies.

To guard against an earthquake striking Tokyo or Japan's southeastern coast, NTT DOCOMO is putting priority on regions centered on Tokyo and Nagoya, and started by installing two large zone base stations in Aichi and Gifu Prefectures in September 2011. In October, it installed another ten such stations in Tokyo and the prefectures of Kanagawa, Nagano and Niigata, followed by further installations throughout the country to bring the nationwide total by the end of February 2012 to 104 large zone base stations.

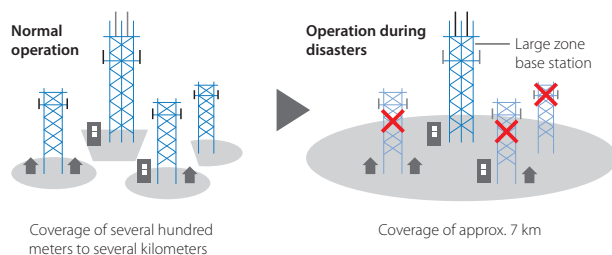



● Disaster readiness

Joint research on the use of mobile spatial statistics for estimating area-specific populations from network operation data



NTT DOCOMO is seeking to contribute to society through the use of mobile spatial statistics. These are statistics derived from the operation data of networks for providing mobile phone services that can be used to estimate area-specific demographic information on an hourly basis. NTT DOCOMO is looking into ways of using such data for the public good in such areas as urban planning and disaster mitigation plans.

In the field of urban planning, for example, it is conducting joint research with the University of Tokyo on monitoring public transport service supply and demand, and on the impartial selection of public park locations. It is also working with Kogakuin University in the field of disaster mitigation planning on research to estimate the number of people who would be stranded in the center of Tokyo or would have to walk home if the city were struck by a serious quake. The researchers found mobile spatial statistics to be useful for estimating both categories.

The results of this research were presented at CEATEC JAPAN 2011, a cutting edge IT and electronics exhibition held at Makuhari Messe in October 2011. The usefulness of mobile spatial statistics to formulating measures for addressing the problem of people stranded in city centers was recognized with the award of the Grand Prix in the Safe and Secure Networks category of the CEATEC AWARDS 2011.

How NTT DOCOMO plans to contribute to society through the use of mobile spatial statistics

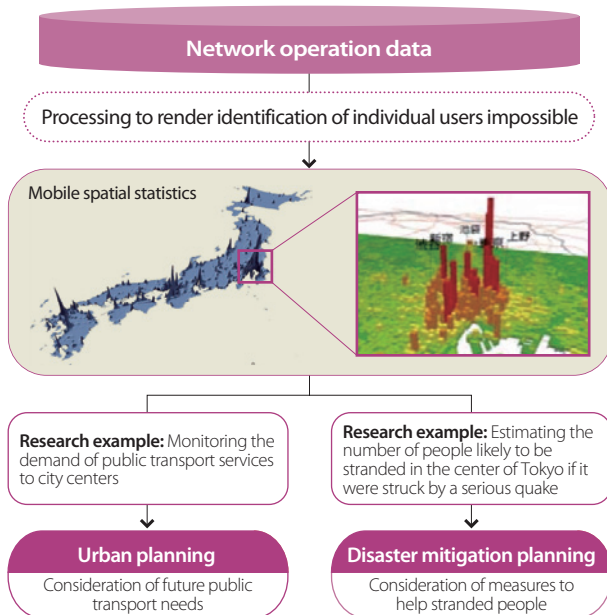

● Various means of checking on the safety of disaster victims

Expanding services for easy safety status checking and information gathering when disaster strikes



To enable people to check on the safety of relatives and friends in areas hit by a major disaster that has caused phone connection problems, the NTT Group provides Disaster Emergency Message Dial (171) for leaving voice messages by phone, Disaster Message Board Service for leaving text messages by mobile phone, and Disaster Emergency Broadband Message Board (Web 171) for leaving text messages via the Internet. When we launch these emergency services in the event of a disaster or other contingency, we promptly inform our customers through the mass media, website and other means.

In the past, mobile phone carriers each provided their own versions of the Disaster Message Board Service, but one-stop search across all of their message boards was enabled on March 1, 2010, and support for smartphones was added on March 18, 2011.

In fiscal 2012, NTT DOCOMO further boosted the convenience of its safety status checking service as part of its new disaster countermeasures. In addition to adding voice guidance to its disaster message board application to facilitate registration and checking of safety status on its Disaster Message Board from smartphones, it launched a Disaster Voice Messaging Service for delivering digital voice messages at times when disasters have incapacitated voice communications.

When a disaster occurs, NTT DOCOMO also lists the Twitter accounts of public agencies and news media on the top pages of its dmenu and iMenu sites to make it even easier for users to collect disaster-related information. It has also enabled the checking of safety status information posted to Google Person Finder from its Disaster Message Board.

How the Disaster Voice Messaging Service works

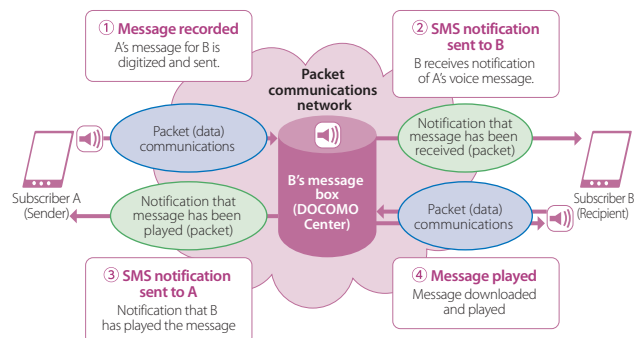



● Practice drills related to communications services

Practice for Disaster Countermeasures Office operation after a large-scale disaster in conjunction with government comprehensive disaster drills



NTT holds disaster drills on Japan's Disaster Prevention Day on September 1 to coincide with the government's annual comprehensive disaster drills held on the same day. For the fiscal 2012 drill, it practiced the operation of a Disaster Countermeasures Office and the setting up of an alternative site for such an office in line with the government's drill scenario for an earthquake centered on Tokyo. The approximately 20 members of the Office checked basic procedures related to emergency call-up and the setting up and operation of the Office, and the system for sharing information between group companies.

NTT Corporation and group companies also participated in the government's comprehensive disaster simulation exercises for an earthquake centered on Tokyo that were held in January 2012. The aim of these exercises was to raise disaster response operational capabilities through role-playing simulations of Disaster Countermeasures Office operations based on government Guidelines for Emergency Response Activities and other guidelines. We also checked the sharing of information with other participants, including the nine participating prefectures and cities of the Greater Tokyo area and other designated public institutions such as railways and major transport companies.

NTT will continue to hold drills linked with the government's comprehensive disaster drills to further develop its knowledge and skills in operating a Disaster Countermeasures Office (including the operation of alternative sites), and to check and test its Disaster Countermeasures Office operation system from the perspective of representing the response of the NTT Group as a whole.

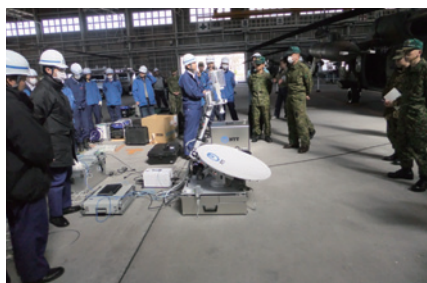

Joint drills with the Japan Self-Defense Forces

● Supporting customer disaster mitigation and response

Leveraging ICT solutions to support business continuity when disasters strike



NTT Communications provides various ICT solutions for helping companies to draw up business continuity plans (BCP) and mitigate the risks to their business and employees posed by natural disasters such as earthquakes and typhoons, terror, pandemics and other contingencies.

One such solution is Safety Check/Mass Notification Service, a BizCITY SaaS application for collecting and collating the safety status of employees and their families in the event of disasters and other emergency situations, and for the mass issue of emergency instructions. Another is Earthquake Newsflash Distribution Service, which can also be integrated with elevator stoppage and other equipment control requirements. By providing solutions such as these, NTT Communications helps to support the business continuity of its customers by protecting the safety of employees and mitigating damage.

Another NTT Communications solution is Biz Desktop Pro, a desktop virtualization service for creating virtual desktops in the cloud that are exact copies of physical desktops within the company, and can be accessed remotely from anywhere at any time. A great many companies using this service confirmed after the Great East Japan Earthquake that it had enabled their employees to access their virtual desktops from home or elsewhere when power outages or other factors made commuting impossible, and that business continuity was maintained as a result. Interest in this service has grown steeply since the earthquake from the need to save electricity by having employees work from home.

NTT Communications will continue to support business continuity in emergency situations through providing ICT solutions for protecting corporate information assets.



● Supporting customer disaster mitigation and response

Providing satellite telephone services to secure stable communications when disaster strikes



NTT DOCOMO offers WIDESTAR II as a satellite telephone service that can provide stable and largely disaster and weather-resistant communications around the clock. WIDESTAR II uses two geostationary satellites positioned over the equator to cover all of Japan, including its coastal waters up to about 200 nautical miles. In addition to disasters, it can also be used as a means of communication in mountainous areas and on islands and ships, providing voice, data and fax communications services.

WIDESTAR II is a high-speed service providing maximum downlink/uplink speeds of 384 kbps and 144 kbps respectively¹. WIDESTAR II also includes convenient optional services such as exclusive subscriber channels, PtoP² communications that use only the WIDESTAR network, and simultaneous broadcast to a maximum of 200 destinations. As of the end of March 2012, the number of WIDESTAR II subscribers had risen to about 10,000 (out of a total of approximately 40,000 for all DOCOMO satellite telephone services), with mass media, banks and manufacturers as well as local authorities and other public institutions among its users.

DOCOMO plans to respond to increasingly sophisticated and diverse needs by developing new solutions including integration of WIDESTAR with video streaming, data communications, Wi-Fi devices and smartphones.

1. The data rate is the maximum value of the technical specification when sending and receiving, and does not represent the actual data rate. Communications are provided on a best-effort basis. The actual data rate may differ depending on the communications environment and network congestion.

2. Point to Point

Communications restricted to two endpoints



WIDESTAR II satellite phone terminal

Developing seismic resistance technologies for telecommunications equipment and non-structural elements



NTT FACILITIES is endeavoring to ensure the seismic resistance of telecommunications equipment by conducting vibration experiments to assess the resistance of equipment located on building floors when shaken by earthquakes.

For these experiments, it is using DUAL FORCE, a 3D vibration experiment system that it started to use in 2010 with the aim of developing technologies for countering the kind of long period ground motions that are anticipated in the event of a serious quake along the Nankai Trough. In October 2011, NTT FACILITIES used DUAL FORCE and other vibration experiment devices to conduct experiments on the impact of long period ground motion on its FIT Floor double floors and steel frames etc. for supporting telecommunications racks and other equipment, and on air conditioning equipment. These experiments showed that the tested equipment was unaffected by long period ground motions, demonstrating the effectiveness of existing material strength design methodology. Moving forward, NTT FACILITIES plans to use DUAL FORCE to develop long period ground motion seismic resistance evaluation techniques and seismic resistance technologies for various other equipment in addition to telecommunications equipment.

In addition to damage inflicted by the Great East Japan Earthquake tsunami, the tremors themselves caused extensive damage to secondary structural elements and equipment. NTT FACILITIES has accordingly focused in particular on how tremors affect suspended equipment because of the risk that such equipment poses to people if it drops. Using DUAL FORCE, the company conducted experiments to reproduce the dropping of full-scale air conditioners to investigate the factors causing them to drop and develop technologies for making them more resistant to earthquakes.

NTT FACILITIES will continue these efforts to create a safer society by further developing seismic resistance technologies for non-structural elements as a business continuity planning research goal.



Using DUAL FORCE to conduct experiments



● Supporting customer disaster mitigation and response

Providing SmartCloud as a service to support enterprise business continuity in emergencies



NTT COMWARE launched SmartCloud in 2010 as a cloud-based service to support enterprise business continuity planning (BCP) for major disasters or other emergency situations by enabling continued use of company information systems and providing an environment for the continued execution of business tasks.

SmartCloud is underpinned by 24/365 operation and data centers with outstanding disaster resistance. In-house power generators capable of supplying power for over 72 hours and contracts for the preferential supply of fuel are among the means used by NTT COMWARE to secure alternatives, enable continued use of IT systems, and protect the information assets of its SmartCloud customers in emergencies. In fiscal 2012, the company added Nagano and Hokkaido to its main data center locations, bringing the domestic total to six.

NTT COMWARE is steadily expanding its SmartCloud lineup, which includes the SmartCloud Desktop virtual desktop service, Smart Cloud Virtual Server and SmartCloud Mail. In fiscal 2012, it added teleworking, backup and other business continuity solutions by combining services, making SmartCloud even easier to use as a BCP solution to guard against disasters, power outages and other contingencies.

NTT COMWARE won recognition for these cloud services when it was selected in February 2012 as one of the 14 best cloud era brands in Nikkei BP's 4th Cloud Rankings.



Example of backup solution

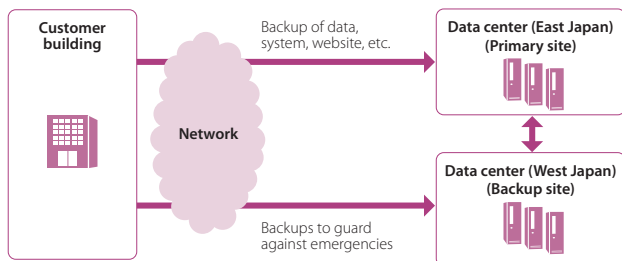



● R&D for maintaining and improving information security

Research on quantum cryptography, the ultimate security



The provision of information security sufficient to ensure safe online commerce, protect personal information and prevent the leakage of confidential information is a matter of increasing importance. RSA, which is currently the most widely used encryption technology, depends on the computational difficulty of integer factorization as the basis for its security, but with increasingly powerful computing, integer factorization may no longer constitute an impossible hurdle. For this reason, quantum cryptography that makes use of the quantum properties of photons is being increasingly studied as an absolutely secure next-generation encryption method.

As a step towards the practical implementation of quantum cryptography, NTT Basic Research Laboratories succeeded in 2007 in using a single photon to distribute a cryptographic key over a 200 km optical fiber, a world record. In 2009, NTT furnished theoretical proof that its differential phase shift quantum key distribution (DPS-QKD) protocol guarantees security at the single photon level. In the same year, it also attained secure key generation rates of over 1 Mbit/s for quantum key distribution and demonstrated the security of DPS-QKD using single photons.

To test these achievements in a working environment, it conducted further experiments in 2010 on its DPS-QKD quantum cryptography system using a 90 km loop-back experimental optical fiber network between Koganei and Otemachi in Tokyo. In these experiments, it achieved sustained secure key distribution with a generation rate of 2 kbit/s.

In 2011, it launched experiments to test the long-term stability of its system when connected to an actual commercial optical network linking the center of Tokyo to Western Tokyo (Tama area). It continues its investigations to identify operational and system management issues.

Because the security of quantum encryption is grounded in the physical properties of light, it can never be decrypted using computer-based cryptographic decoding technologies. NTT will continue to research quantum cryptography with the aim of enabling communications that can never be eavesdropped.

Development of cloud-based cryptographic key storage to resolve online data protection issues



NTT has developed a new cloud-based cryptographic key storage mechanism for resolving online data protection issues.

Decrypting encrypted data has traditionally involved the use of a decryption key that the user is required to store on a local device or smart card etc., leaving data owners exposed to the risk of information leaks as a result of lax key management. Because NTT's cloud-based cryptographic key storage mechanism keeps and manages decryption keys on the cloud and safely consigns decryption of encrypted data to the cloud, it relieves the user of the bother of managing decryption keys and effectively eliminates the risks of information leaks through lax key management.

At the core of the new system is self-correction technology that corrects errors and bogus data. The safety of consigning key decryption to the cloud cannot be assured unless the system also includes the means to detect incorrect decryption results. NTT Secure Platform Laboratories accordingly leveraged its many years of basic research in cryptography to develop a self-correction technique that uses mathematical principles to ensure its security and prevent unauthorized access and tampering with encrypted data, thus guaranteeing the safety of consigning decryption to the cloud.

NTT is now researching the practical implementation of this cloud-based cryptographic key storage mechanism for general business use. Researchers are investigating real world security aspects from both system design and operation viewpoints while also studying the social role of this technology, and NTT aims to make a commercial system available within two or three years.

How cloud-based cryptographic key storage works

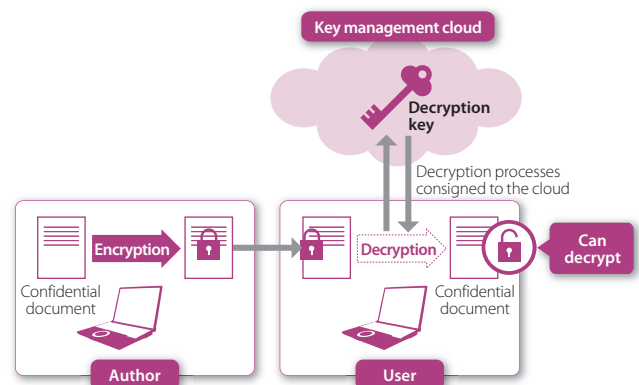



● Promoting and supporting information security management

NTT CERT: Supporting security across the NTT Group



A computer security incident response team (CSIRT) is an organization that gathers information on computer security threats, investigating them and implementing appropriate response activities. NTT-CERT, operated by NTT Secure Platform Laboratories¹, is the CSIRT for the NTT Group.

In addition to handling inquiries regarding NTT Group information security, NTT-CERT also works with security managers and system administrators of group companies to minimize security threats. It helps, for example, to test the security of Web servers used by group companies, as well as conducting experiments and providing consulting support related to the security of the next-generation network (NGN)² provided by NTT East and NTT West.

In fiscal 2012, it received an increasing number of inquiries from group companies in the face of growing domestic and overseas cyber attack risks, and strove to provide stable handling as NTT-CERT while also working to enhance the NTT Group's ability to counter security threats by expanding its public monitoring operations and building up its forensic investigation capabilities and knowledge.

In the area of security analysis and evaluation, NTT-CERT expanded its list of recipients for vulnerability information, bolstered its security product evaluation capability, drew up technical documents on security measures for the Android platform and virtualization, and otherwise raised its security analysis and evaluation capabilities while also sharing its knowledge with group companies.

NTT-CERT contributes to improving the security level not only of the NTT Group, but also of Japan as a whole by providing its know-how to help other members of the Nippon CSIRT Association³ to establish their own CSIRTs, as well as helping to recruit members to the Association and promoting its activities.

1. Created when NTT Information Sharing Platform Laboratories was reorganized in fiscal 2012

2. NGN (next-generation network)

A telecommunications network that combines the reliability and stability of conventional telephone networks with the flexibility and economy of high-speed, high-capacity IP networks. NTT has led the world in bringing NGN to fruition, and has launched commercial NGN services.

3. Nippon CSIRT Association

A Japanese CSIRT organization established in April 2007 by NTT-CERT, JPCERT/CC and others

Expanding MagicConnect mobile lineup to enable simple and secure remote access to company PCs



NTT IT's MagicConnect personal remote access USB keys enable access to a specific company PC just by insertion into any other PC.

In May 2010, NTT IT released MagicConnect Fingerprint Authentication USB Key as a new product that adds fingerprint authentication to unique USB key hardware information and password for businesses whose security policies require biometric authentication. In February 2012, the company also started to offer MagicConnect Mobile, which enables simple and secure remote access to company PCs from Android devices and iPads.

These products have been designed for security, enabling employees to access files from remote locations without removing them from the company, and thus preventing the intrusion of malware. Because they allow easy and secure access to company PCs and servers from home PCs and other personal devices as well as from Android devices and iPads provided by the company, MagicConnect products are being widely used for teleworking and mobile work. They have been selected for awards such as the Telework Promotion Award for Excellence and SOHO Awards Jury Award, and were by the end of fiscal 2012 being used by about 1,800 businesses and other organizations.

MagicConnect Mobile usage scenario

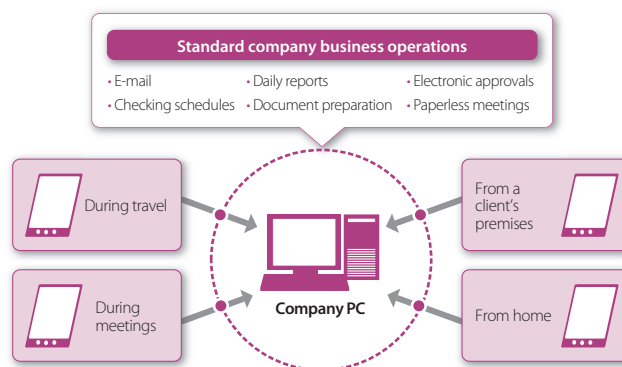



● Protecting the personal information of customers

Group company initiatives to enhance the protection of customer information



The NTT Group has established an NTT Group Information Security Policy that states its position on information security, and is doing its utmost on a groupwide basis to protect the personal information of its customers and prevent information leaks.

NTT East

- Promotion of integrated company-wide information security management through its Information Security Department, an organization that reports directly to the president
- Further enhancement of employee education related to information security through training and activities to raise awareness
- Stronger technological measures to ensure information security, including functions for preventing e-mails and other information from being sent to the wrong address
- Use of physical measures such as the installation of cameras and biometric authentication-based entry and exit controls to bolster information security

NTT West

- Establishment of a Customer Information Protection Reinforcement Period and Information Security Awareness Period, and implementation of education, training, and checks to boost employee awareness and ensure information management fundamentals are being observed
- Use of information takeout ledgers to manage the taking out of personal information from company premises
- Limiting of work terminals enabling copying of data to external recording media
- Limiting of external recording media used to keep customer information to USB memory sticks equipped with fingerprint authentication functions
- Introduction of a system to limit employees able to send e-mails with attachments to destinations outside the company to those with prior permission, and to prevent such employees from sending such e-mails unless they are CCed to superiors too

NTT Communications

- Yearly training according to level (yearly information security training for all employees, including directors and temporary staff, using video and educational texts followed by e-learning to measure understanding. Also training for IT system administrators etc.)
- Vulnerability diagnosis performed on information systems, including those of group companies, to protect them from Internet security threats
- Reinforcement of security governance as a group through

conducting security surveys of domestic and overseas group companies

NTT DOCOMO

- Holding of regular Information Management Committee meetings chaired by the Chief Privacy Officer (Senior Executive Vice President) to consider and promote personal information protection and periodically check and survey personal information management and operations status
- Creation of learning tools covering personal information handling and management methods, and implementation of repeated and continuous training for directors, employees, temporary staff, docomo Shop (business partner) personnel, etc.
- Provision of e-learning for all employees, including managers, on the importance of strict information security compliance

NTT DATA

- Establishment of internal rules regarding the appropriate handling of personal information, together with appropriate review and revision in line with advances in information technology and social change
- Yearly implementation of personal information protection self-evaluation according to individual, organization and system
- In-house training (training according to level, e-learning-based training, training focused on the protection of individual rights)
- Creation and distribution of a handbook on information security

NTT FACILITIES

- Nationwide acquisition of ISO 27001 certification from 2006, and continued implementation of information security activities
- Provision of e-learning-based training for all employees
- Limitation of USB memory sticks used for work to those provided by the company that are equipped with fingerprint authentication to restrict access
- Use of terminal management tools to prevent the connection of USB-based external recording media other than USB memory sticks permitted by the company

NTT COMWARE

- Establishment of rules based on the Personal Information Protection Law, ISO 15001 and ISO 27001, acquisition of PrivacyMark in 1999, continued implementation of information security activities and personal information protection, including the handling of customer information and measures based on rules
- In-house training (training according to role, e-learning-based training for all employees, including those of partner companies)

NTT Urban Development

- Provision of training for all employees
- Strict account management and allocation of company IT system access rights according to authority level
- Strict supervision of personal information handling by subcontractors



● Promoting safe and secure ICT use and user etiquette

Nationwide staging of NTT Dream Kids Net Town fun events to learn about telecommunications



The NTT Group held NTT Dream Kids Net Town 2011 as a series of summer vacation events for children.

These events are staged jointly each year by NTT, NTT East, NTT West, NTT Communications, NTT DOCOMO and NTT DATA, with 2011 being the sixth year. The events are designed to enable the children to learn about the fun and convenience of Internet, smartphones and other ICT services through actually experiencing them, while at the same time learning rules and manners for their safe and secure use. The events also serve as ideal content for summer vacation study assignments.

Net Town events have in previous years been open only to 4th to 6th graders, but with children being exposed to ICT services at younger ages now, the fiscal 2012 events were opened to 3rd graders too, and attracted a total of about 1,300 children nationwide. During the event period, we also opened a learning site for children unable to participate in the actual events.



Dream Kids Net Town event

Providing e-Net Caravan instructors to help protect children from Internet-related trouble



NTT East, NTT West and NTT DOCOMO provide employees as instructors for e-Net Caravan, an initiative organized by the Ministry of Internal Affairs and Communications and others to protect children from computer viruses, spam e-mail, theft of personal information, fraudulent claims and other Internet-related trouble. Instructors give talks on safe Internet use for parents/guardians and school personnel as well as students. These talks have been held throughout Japan since fiscal 2007.

In fiscal 2012, the three companies provided instructors for 197 talks nationwide that were attended by 6,222 parents/guardians and teachers and 13,778 students.

WEB e-Net Caravan
<http://www.e-netcaravan.jp/> (in Japanese only)



e-Net Caravan screenshot



● Providing services to ensure child safety

Providing local authorities with ICT systems for ensuring the safety of children traveling to and from school



Owing to the merging and closure of schools in mountainous areas in response to declining birthrate and depopulation, many children in such areas now travel to and from school by school bus. Because many parents/guardians are anxious about the long time that such travel often requires, NTT West developed an ICT system for ensuring the safety of children traveling to and from school by school bus. Following field trials conducted under a Ministry of Internal Affairs and Communications Service Model of ICT Systems for Monitoring Children in Local Communities project, the system went into full operation at seven elementary schools in the city of Himi in Toyama Prefecture in fiscal 2010.

The system enables parents/guardians to keep track of school bus movements and when their children get on or off a school bus through the use of a GPS for providing information on the geographical position of school buses, and smart tags attached to the school bags of children that are capable of wireless transmission of positional and other information of the child concerned. In addition to enabling parents/guardians to check bus and child movements through the Internet or local intranet, the system also automatically sends e-mails to them when their children get on or off a school bus.

In fiscal 2011, under the Ministry of Internal Affairs and Communications' Ubiquitous Town Concept project to promote the use of ubiquitous computing to benefit local communities, NTT West extended coverage to a further five schools in the city and enhanced the system to include first and second graders who walk to school, thus allowing parents/guardians to keep track of their children's movements irrespective of the means they use to travel to and from school. From April 2012, third graders walking to and from school were also added, bringing the number of children covered by the system to 902 by May 2012.

In a questionnaire survey of system users conducted in fiscal 2012, a large majority responded either that the system is "very useful" or "useful, but could do with improvements".

NTT West will continue to support the operation of this system so as to help protect elementary school children and reassure parents/guardians and school personnel of their safety.

Protecting children from sex crime by restricting access to child pornography sites



Blocking child pornography on the Internet is important from the perspective of protecting children's rights and ensuring a safe Internet usage environment. The Comprehensive Measures to Eliminate Child Pornography announced by the Ministerial Meeting Concerning Measures Against Crime in July 2010 called for all relevant government ministries and agencies to prepare the ground for Internet service providers (ISPs) and other related businesses to voluntarily block child pornography.

As a result, the Internet Content Safety Association (ICSA) was established in March 2011 to manage a child pornography site address list, and started to provide a list of such sites in April 2011 for the ISPs that make up its membership.

NTT Communications Group providers OCN and Plala have since blocked access to child pornography sites and images based on ICSA's address list.

In fiscal 2012, OCN also participated in a child pornography blocking field trial organized by the Ministry of Internal Affairs and Communications. OCN plans to share the knowledge it gained through this participation with other ISPs and encourage those that have not yet taken such steps to start blocking access to child pornography sites.

Child pornography constitutes a serious violation of children's rights, and the NTT Communications Group will continue to work with ICSA to implement measures to prevent such violations by blocking the distribution of child pornography.



● Pursuing customer satisfaction

Leveraging customer feedback to implement improvements and develop new services



NTT East leverages customer feedback to implement improvements and develop new services.

Customers provide NTT East with opinions, requests, and both positive and negative feedback through its Customer Consultation Center and other channels. Opinions and requests are discussed from various perspectives at “Smile Working” sessions before being passed on to a Smile Committee chaired by the president for final deliberation. Decisions taken by this committee are shared with the whole company. Positive feedback is used to encourage efforts to boost customer satisfaction by commending the employees concerned at twice-yearly presentations. Negative feedback is taken very seriously by the whole company, with information being shared with relevant sections, and actions taken to prevent recurrence of complaints.

In fiscal 2012, NTT East’s customer consultation service handled over 140,000 inquiries, and held eight Smile Working sessions and two Smile Committee meetings to consider 135 potential improvements distilled from opinions and requests.

A sample of customer opinions and the improvements they prompted in fiscal 2012

Customer opinions	Improvements
NTT East and NTT West Customer Consultation Centers use the same phone numbers. Could you give them different numbers?	We enabled customers to choose between NTT East and NTT West Customer Consultation Centers when calling.
Could you increase the size of the text in the Hello Information newsletters and also simplify the coloring?	We changed the size of Hello Information newsletter text, and also simplified the coloring.
Could you supply @Billing statements in PDF as well as CSV format?	We started providing electronic billing statements in PDF as well as CSV format, and introduced other improvements to facilitate printing and saving.



● Pursuing customer satisfaction

Customer First Activities for leveraging customer feedback to improve services



NTT West takes the opinions and suggestions of its customers very seriously. It has long endeavored to look at its business from the customer's perspective and evolve together with its customers by making its Customers First Activities one of the pillars of its business operations.

Under this initiative, its Customers First Activities Working Group examines and discusses feedback provided by its customers through its 116 customer information line and other channels, decides courses of action for making improvements across the Group, and reflects feedback in service improvements.

In fiscal 2012 too, it made 81 improvements to services based on customer feedback. For example, it received a customer request for a handy Disaster Emergency Message Dial (171) user guide, and created a simple PDF guide designed to be cut out and folded into a convenient credit card size after downloading and printing. Another customer complained that the website for checking system maintenance schedules and malfunction information was difficult to find and understand, and so NTT West updated the website to make it easier to use, adding search functions and extending the display period for information from about two weeks to three months.

It also publishes details of customer feedback that has led to actual improvements on its website.



Customer First Activities screenshot

DOCOMO rated No.1 in customer satisfaction survey



Being Japan's No.1 mobile phone service provider in terms of customer satisfaction is one of DOCOMO's business goals, and it exerts itself in many directions to achieve this goal. These efforts resulted in DOCOMO being rated as No.1 for overall customer satisfaction in Japan for the second year in succession for consumer users¹, and third year in succession for business users² in international market research firm J.D. Power Asia Pacific's 2011 Japan Mobile Phone Service Study.

1. According to the results of the J.D. Power Asia Pacific 2011 Japan Mobile Phone Service StudySM, which obtained responses from 31,200 consumer mobile phone users in Japan during the survey period in August 2011 http://www.jdpower.co.jp/jdp_e/index.html
2. According to the results of the J.D. Power Asia Pacific 2011 Japan Business Mobile Phone Service StudySM, which obtained 3,214 responses from 2,466 companies with 100 or more employees regarding mobile phone and PHS service providers in Japan (with companies allowed to rate up to two mobile phone/PHS service providers)

WEB

Customer First Activities

<http://www.ntt-west.co.jp/withc/> (in Japanese only)

Structure for promoting Customer First Activities

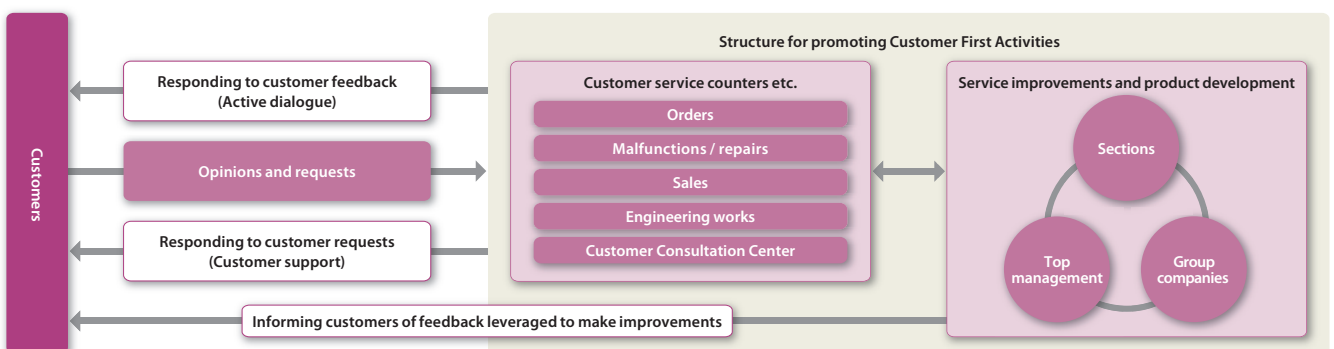



● Building a quality management framework and making quality improvements

Building a quality management framework



To provide telecommunications services that will meet the expectations of its customers, the NTT Group is constantly striving to improve its technologies and the quality of its products and services, and provide a safe and secure platform for ubiquitous broadband communications.

As part of these efforts, group companies have built quality management systems and obtained ISO 9001 certification and other quality management international standard certification according to the nature of their business. Logistics outsourcing specialist NTT LOGISCO, for example, also earned ISO 13485 certification for medical devices industry quality management in 2005 so as to provide medical equipment makers with logistics services that they could use with confidence, and NTT Communications in 2009 became certified for COPC-2000, a quality management standard designed specifically for call center services, so as to provide even higher quality support to its customers and further cultivate trust in its ICT services.

In fiscal 2012, NTT COMWARE, which provides data center services at six domestic sites, earned ISAE 3402/SSAE 16 Type II* attestation for reporting description, design and operating effectiveness of a service organization's business procedures and internal controls.

*ISAE 3402: International Standard on Assurance Engagements No. 3402, Assurance Reports on Controls at a Service Organization, issued in December 2009 by the International Federation of Accountants (IFAC)/SSAE 16: Statement on Standards for Attestation Engagements (SSAE) No. 16, Reporting on Controls at a Service Organization, issued in April 2010 by the American Institute of Certified Public Accountants (AICPA). Successors to the Statement on Auditing Standards No. 70 (SAS 70), ISAE 3402/SSAE 16 report on controls at a service organization which are relevant to user entities' internal control over financial reporting. Type I reports include the service auditor's opinion on the service organization's description of controls and the suitability of the design of the controls to achieve the specified control objectives. Type II reports include the service auditor's opinion, based on detailed testing, on whether the specific controls were operating effectively during the period under review, as well as the information contained in Type I reports.

Regular meetings held by Appropriate Advertising Oversight Committee



In addition to setting and promoting compliance with advertising materials vetting criteria and rules through its Advertising Review Office, NTT East holds regular Appropriate Advertising Oversight Committee meetings chaired by a Senior Executive Vice President to discuss group policies regarding advertising materials and check on the status of implementation of those policies. Since June 2008, NTT East has also required all advertising materials to be vetted for appropriateness by its Advertising Review Office as well as the creators prior to use.

In fiscal 2012, the company vetted 9,660 items. It also endeavored to further ensure appropriate advertising by checking the operation of its vetting system and, as it did the previous fiscal year, holding seminars for employees to explain the Act Against Unjustifiable Premiums and Misleading Representations and key points about producing advertising materials that are easy for customers to understand.

In fiscal 2013, NTT East plans to further promote appropriate advertising by using customer monitor surveys and other means to check that its advertising materials are easy to understand from the outsider perspective.

NTT East will continue its efforts to ensure compliance with relevant laws and regulations and the provision of clear-worded and easily understandable advertising materials through further institutionalizing vetting practices and improving the quality of its advertising materials.



● Building a quality management framework and making quality improvements

Working with overseas telecommunications partners to improve global network quality



NTT Communications holds an annual Arcstar Carrier Forum (ACF) to provide its customers with stable networks and address growing business continuity demands.

NTT Communications has held ACF since 2000 to gather its overseas telecommunications partners under one roof with the aim of improving the quality of its global network service operations. Far-ranging discussions are held every year on subjects such as methods for resolving malfunctions and integration issues, infrastructure design and integration processes aimed at preventing problems from occurring and operation support systems that enable the prompt analysis and resolution of problems.

In fiscal 2012, NTT Communications held ACF2011 on November 15-16 in Kobe to discuss measures for improving the quality of its Arcstar global network services and share operational expertise and improvement examples with 21 participating major overseas telecommunications companies. It also reported on the impacts of the Great East Japan Earthquake on its communications services, and on related recovery efforts.

NTT Communications will continue to work for the overall improvement of its global network through leveraging ACF and other means to accumulate further expertise to improve the operations and quality of its international data communications services, reduce failure rates and ensure the real-time provision of information to customers by carriers.



Arcstar Carrier Forum



● Promotion of universal design

Promoting the use of universal design to provide ICT services that are easy for everyone to use



NTT Service Evolution Laboratories' ICT Design Center devotes itself to the development of design techniques for providing ICT services that elderly people and novice users as well as ordinary people will find easy to use, and will want to use. It also helps to promote the use of universal design in ICT among NTT Group companies and employees.

For example, it conducts a great many user evaluation experiments on ICT device connection and configuration to assist in the design of instruction manuals that enable customers to connect and configure devices without any hitches. NTT East and NTT West apply the findings of these experiments to their product manuals.

Making communications devices easier for anyone to use, and improving information provision



Based on the Telecommunications Accessibility Guidelines for Older Persons and Persons with Disabilities issued by the Info-Communication Access Council*, NTT West continues to improve the accessibility of its public and other telephones, and to make the information that it provides easier to understand.

For example, it is installing public telephone boxes for wheelchair users, and public telephones equipped with receiver volume controls for people with hearing impairments, and card and coin slot braille signage for the visually impaired. It is also deploying digital public telephones featuring universal design components such as large and easy-to-read keys and LCD displays.

NTT West also offers a telephone with a bone conduction receiver to communicate the voice of the other party by vibration through the bone behind the ear or elsewhere for people with hearing impairments, and has since fiscal 2012 offered three types of phone equipped with an emergency notification system that enables up to three preset destinations — usually the phone



Public telephone box for wheelchair users

numbers of family or friends — to be called just by pressing a special button on the phone's main unit.

NTT West has also established a structure for leveraging customer feedback received by the NTT Communications Equipment Consultation Center and other channels to make

improvements to communications device settings. Where the provision of information is concerned, it endeavors to make information accessible to all, and enables visitors to its website to choose between three font sizes to view content.

***Info-Communication Access Council**

An organization created to promote the balanced development of telecommunications equipment that is easy for anyone, including older persons and people with disabilities, to use

Lectures and training for promoting the spread of universal design and accessibility

NTT CLARUTY CORPORATION

To educate website designers and administrators as well as those involved in assisting people with disabilities, NTT CLARUTY provides a range of training and lectures on universal design and the do's and don'ts of creating accessible websites that are easy for anyone to use.

In fiscal 2012 too, NTT CLARUTY held lectures and training workshops for local authority website administrators to raise awareness regarding accessibility. In addition to giving two lectures at Web Accessibility Seminar events organized by the Japan Web Accessibility Consortium, it gave lectures at seminars held by corporate members of the Consortium to present an expert perspective on Web accessibility, and held four training workshops on the same subject for Tokyo Metropolitan Government and Fukushima Prefecture officials.

NTT CLARUTY also gives lectures and training workshops on universal design and the barrier-free provision of information at training courses for instructors involved in expanding the work opportunities of people with severe visual impairments at Polytechnic University and at many other courses for training instructors in the provision of assistance to people with disabilities.

NTT CLARUTY plans to expand such lectures and training for local authority and private sector personnel, students and other people involved in various fields in assisting people with disabilities.

It is also developing the content of the course in sign language that it already provides to NTT Group companies so as to enable it to offer the same course to other organizations outside the Group.



An NTT CLARUTY lecture

Team NTT communication

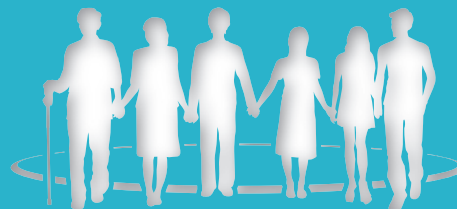

Goal 1

Activities that contribute to respect for diversity and equal opportunity

Goal 2

Creating safe and healthy workplaces

Goal 3

Corporate citizenship activities

As Team NTT, we are committed to contributing to the creation of flourishing communities.

We endeavor to conduct our business according to the highest ethical standards and awareness of human rights, and to create workplaces where diversity is respected and all employees are able to realize their full potential.

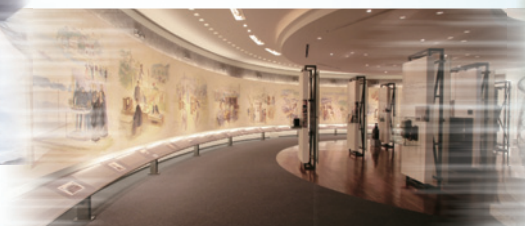



● Creating workplaces where everyone can realize their full potential

Ensuring diversity



The NTT Group has always striven to create diverse workplaces in which people can realize their full potential irrespective of sex, age, race, nationality, disability or other factors. In October 2007, NTT established a Diversity Promotion Office to bolster workplace diversity efforts across the whole group, and by April 2008, diversity promotion supervisors were in place in group companies.



Communication Handbook

The Diversity Promotion Office has since worked with these diversity promotion supervisors to support work-life balance improvements and career development for an increasing diversity of employees, and conduct educational activities aimed at reforming corporate culture and ingrained practices.



Diversity Promotion Office screenshot

Employment in the NTT Group

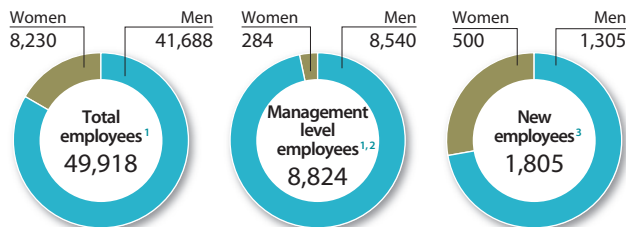

The above data represents eight core NTT Group companies: NTT, NTT East, NTT West, NTT Communications, NTT DATA, NTT DOCOMO, NTT FACILITIES and NTT COMWARE.

- 1. As of March 31, 2012
- 2. Section managers and above
- 3. As of April 1, 2012

Expanding employment of people with disabilities



The NTT Group actively recruits people with disabilities and endeavors to expand hiring opportunities for them. Following NTT's establishment of NTT CLARUTY in 2004 and NTT DATA's of NTT DATA DAICHI in 2008, NTT West founded NTT WEST LUCENT in July 2009 as the third special purpose subsidiary within the NTT Group.

NTT CLARUTY

NTT CLARUTY works for the expansion of employment opportunities for people with intellectual disabilities, as well as operating the Yu Yu Yu information portal site for people with disabilities and elderly people, universal design/accessibility support services, printed material digitization service and a call center business. In June 2011, it launched a calendar production business that makes use of recycled paper and hired 28 people with intellectual disabilities, and in April 2012, a business involved in direct marketing and solicitation of subscribers to ICT device fixed price maintenance services that by July employed 24 people with physical and physiological disabilities.

NTT CLARUTY also actively provides workplace training and workplace tours. In fiscal 2012, it provided such training to organizations that train job coaches specializing in disabled employment (4 persons, 2 times), and workplace tours to groups from special needs schools with students wishing to find work (12 tours for 96 persons), employment support and other organizations (8 tours for 60 persons) and NTT Group and other companies (12 tours for 76 persons).

NTT CLARUTY furthermore provides NTT Group companies with information and expertise on procedures for hiring people with disabilities, employment management, and the creation of workplaces that address a diversity of disabilities. Employment of people with disabilities in NTT CLARUTY-affiliated companies* stood at 1.96% on June 1, 2012, exceeding the mandatory employment quota of 1.8% for people with disabilities.



NTT CLARUTY workplace

*NTT companies certified as affiliates of NTT CLARUTY special purpose subsidiary
NTT, NTT East and 31 other NTT companies



● Creating workplaces where everyone can realize their full potential

NTT DATA DAICHI

NTT DATA has long employed people with disabilities in areas such as system development and sales, but to enable more people with disabilities to realize their full potential, it established NTT DATA DAICHI in July 2008 as a special purpose subsidiary for creating work opportunities for people with various disabilities. The company provides a Web accessibility diagnosis service, as well as being involved in website production, telephone switchboard/line management, forestry dairy farming and other businesses.

In fiscal 2012, NTT DATA DAICHI not only grew its website production business, but also expanded its lines of business and created more work opportunities for people with disabilities by launching a records management service and other businesses. As a result, employment of people with disabilities in the NTT DATA Group stood at 1.95% on June 1, 2012.

NTT DATA will continue to promote the stable operation and expansion of existing businesses and the hiring of people with disabilities with the aim of boosting its percentage of employees with disabilities to 2%.



NTT DATA DAICHI workplace

NTT WEST LUCENT

NTT WEST LUCENT launched operations in September 2009 as a special purpose subsidiary of the NTT West Group. In addition to a document digitization service, it operates a digital map production and maintenance service business that utilizes broadband networks to create teleworking opportunities for people with disabilities that prevent them from traveling to work. In fiscal 2012, it launched Dream Ark, a portal site for elderly persons and people with disabilities, and also actively provided workplace training to special needs school students (5 students, 4 times in fiscal 2012) as a registered Osaka Prefecture Employment for the Disabled Support Company. Employment of people with disabilities at NTT WEST LUCENT-affiliated companies stood at 1.87% on June 1, 2012, increasing from the previous year and exceeding the mandatory employment quota of 1.8% for people with disabilities.



NTT WEST LUCENT workplace

NTT DOCOMO

NTT DOCOMO actively hires people with disabilities in the belief that supporting their independence is one of its corporate social responsibilities. As of the end of March 2012, it employs 209 people with disabilities, which at 2.07%* of its workforce exceeds the mandatory employment quota for people with disabilities.

*Figure for NTT DOCOMO, INC.



- Creating workplaces where everyone can realize their full potential

Strengthening female career development and doubling the number of female managers



The NTT East Group regards diversity management as an important aspect of driving its growth as a provider of comprehensive ICT services to the general public. Since launching its Diversity Promotion Office in April 2008, NTT East has implemented a range of diversity policies and programs, but to take these initiatives even further, it has set forth a clear vision for implementation from fiscal 2013. It also drew up a statement of commitment that explains its approach to diversity management in simple terms.

In fiscal 2013, NTT East set itself the target of boosting the number of female managers from 140 as of March 2012 to 300 by the end of fiscal 2017, and is planning to further strengthen female career development through expanding its training programs for female employees.

By leveraging diversity management to motivate its employees to aim high, work hard and demonstrate what they're capable of, the NTT East Group aims to boost its corporate value and contribute to the creation of a prosperous society.

Diversity Vision

Turning passion into power, and motivation into innovation

Diversity Commitment

The NTT East Group is committed to the continued innovation of communications for keeping people connected. To achieve this mission, we respect diversity, and expect each and every employee to aspire to great things. We innovate through getting our people to inspire and uplift each other, and we aim to contribute as a corporate citizen to the creation of a prosperous society by providing our people with an environment in which they can work with pride, passion and confidence to further develop our corporate strengths.

Our three diversity policies

1. Help employees to develop their careers.
2. Improve productivity by promoting a healthy work-life balance.
3. Promote diversity through proactive initiatives.

- Supporting teleworking, childrearing and family care

Encouraging the use of childrearing and family care programs



The NTT Group believes in the importance of balancing careers with private life, and offers child care and family care benefits that go beyond legally mandated levels. To address the issue of low birthrate and aging population, we also place no limits on the number of dependents that employees may claim under our family allowance system. In April 2008, NTT's initiatives in this area earned it the Kurumin Mark, a certification provided by the Ministry of Health, Labor and Welfare in recognition of company efforts to support child rearing by employees. Group companies have also obtained the Kurumin Mark.*

We are endeavoring to further improve our childrearing and family care programs to address the needs of employees and revisions in laws. In fiscal 2011, we revised these programs in line with the 2009 revision of the Child and Family Care Leave Law so as to better enable our employees to balance work with childrearing and family care commitments. We have also created NTT-LiFE+, a childrearing and family care support site, on the NTT Group intranet. In addition to providing details and instructions on the use of the various programs, NTT-LiFE+ carries all sorts of other information, including articles about employees who have succeeded in balancing work, childrearing and family care commitments.

We will continue to create an environment that enables our employees to balance work with family care commitments in the coming age when such needs are predicted to become greater than ever. To this end, we plan to hold meetings to exchange views and invite experts to share their knowledge at study sessions.



*Key Kurumin Mark-certified group companies: NTT, NTT East, NTT West, NTT Communications, NTT DOCOMO, NTT DATA, NTT FACILITIES, NTT COMWARE, NTT Software and Nippon Information and Communication



● Supporting teleworking, childrearing and family care

Family Day



NTT West held a Family Day at its head office building in August 2011 to coincide with the summer holidays of employees' children. With the aim of promoting a healthy work-life balance and participation of men in childrearing, the families of NTT West employees working in the head office building were invited to the company to view the offices, have lunch in the employee cafeteria, and tour the NGN Service Operation Center.

Another component of the Family Day event was the exchange of business cards between employees and visiting children after the children were first drilled in the etiquette of business card exchange. The children drew broad smiles with their bright greetings and cute gestures, and the event proved to be a delightful experience not only for the participating families of employees, but also for their superiors and colleagues in every office. Everyone, including employees not participating directly, enjoyed themselves immensely, many commenting that they hoped that Family Day would become a regular event, and that the office would retain the family atmosphere and continue to be a pleasure to work in.



A Family Day business card exchange

Expanding childrearing support programs, and making them easier to use (Egg Garden company creche opens)



Prompted by a suggestion put forward by some employees, in December 2011, NTT DATA opened Egg Garden as a company creche on the ground floor of Toyosu Center Building Annex.

This has relieved employees of worry over lack of nursery vacancies, enabling them to take maternity leave and then return to work as planned. Female employees will hopefully be better able to plan and develop their careers as a result. From the creche's opening up to March 2012, 12 infants were registered for monthly care, and a further six for short-term care.



Egg Garden



● Fair evaluation

Introducing measures for boosting employee motivation and satisfaction with evaluation



The NTT Group implements policies aimed at enabling each and every employee to make the most of their abilities as members of Team NTT, and to grow steadily as competent professionals and take the initiative in developing their careers.

Improving personnel and pay systems

We strive to create personnel and pay systems that reward team play, special skills and other strengths as well as individual performance.

Helping employees to develop their abilities

In addition to group training and OJT to enable employees to gain necessary skills in various fields of business, we provide many other opportunities for employees who are eager to get ahead, including e-learning, distance learning, in-house certification of skill levels, and support for earning qualifications.

We actively support career development, holding management training for those ready to move to the next level in line with their personal goals, as well as enabling employees to discuss career development in personal interviews with their superiors held at the start, middle and end of each fiscal year.

To nurture personnel capable of performing on the world stage, we also send employees to study at overseas graduate schools or participate in overseas trainee programs.

In-house recruitment programs

We raise motivation and promote networking within the Group by providing in-house recruitment programs like NTT Group Job Challenge and NTT Group Venture that present ambitious employees with opportunities to seek new challenges. In fiscal 2012, about 230 employees used such programs to transfer to their desired workplace.



NTT Group Job Challenge screenshot

Enabling non-regular employees to become regular employees



To expand opportunities for various people to fulfill their ambitions, NTT West Group enables non-regular employees of NTT MARKETING ACT, NTT BUSINESS ASSOCIE WEST, TelWel West Nippon, NTT HOMETECHNO and IT-MATE companies who show exceptional skills to become regular employees.

This program is open to employees involved in call center, financial/payroll, SMB/SOHO sales, home repairs, system engineering and other fields. As of April 1, 2012, a cumulative total of 1,585 people have used this program to become regular employees.



● Support for developing capabilities

Nurturing employees capable of performing on the world stage by posting them to overseas companies



To nurture people capable of working in a global capacity, NTT DOCOMO offers a Global OJT program for employees of three years' standing or more to work for one year at an overseas subsidiary or partner company. Global OJT aims to cultivate an international mindset and skills in overseas business practices as well as language proficiency through actual work experience.

In fiscal 2012, DOCOMO sent five employees to the USA, UK, Singapore and Spain. In fiscal 2013, it has further expanded opportunities, sending six employees to work for one year in the USA, UK, Singapore and Germany, and another two employees to work for three months in India. The program, which offers a diversity of training in sales, service planning and development and other areas in line with the careers of the employees concerned, represents an opportunity for employees to gain valuable experience of a kind that would be difficult to come across in Japan.

NTT DOCOMO will review work destinations based on business environment and trends as it continues to implement the program.

Launching Professional CDP, a program to nurture high performers



NTT DATA has launched Professional CDP as a career development program for nurturing employees equipped with advanced expertise and abilities to leverage change. Through this program, NTT DATA supports the efforts of employees to drive their personal growth by certifying their current level of development and providing them with goals to aim for and guidance on how to develop their capabilities to achieve those goals. It is now introducing Professional CDP to NTT DATA Group companies too with the aim of driving the groupwide development of high-performing professionals.

Nurturing capabilities at offshore development sites



NTT DATA outsources some of its system development jobs to overseas subsidiaries, affiliates and partners located in China, India,

Vietnam and other countries. The volume of such outsourced work has grown in recent years, and in its medium term business plan, NTT DATA has set a target of raising the ratio of offshore system development work to 10% of the total for fiscal 2013.

However, efficient offshore development of quality systems requires the provision of excellent communications and sharing of development procedures with overseas subcontractors, and a strong focus on quality improvement. NTT DATA is accordingly deploying communications systems that enable smooth information sharing, and providing education and training for employees involved in offshore development and overseas subcontractor employees. In fiscal 2011, it started providing training for system engineers in overseas subcontractors in the form of an e-learning-based basic course and a group training-based advanced course.

In fiscal 2012, 255 system engineers took the basic course and 91 the advanced course. Another 300 or more are expected to take courses in fiscal 2013. NTT DATA is also planning to develop practical training programs based on communications and case studies for software developers in English-speaking countries and Southeast Asia. To provide a continuing education service, it will transfer the management of existing education programs to the NTT DATA UNIVERSITY, its educational organization, and plans to further develop them as official NTT DATA Group education programs.

Nurturing professionals



NTT FACILITIES endeavors to nurture true professionals who have gained advanced skills in their fields of specialization that enable them to constantly come up with the best solutions. To this end, it provides a wide range of specialized technical training according to job type, and encourages employees to gain official qualifications such as 3rd Class Chief Electrical Engineer or 1st Class Registered Architect.

NTT FACILITIES has in recent years also established subsidiaries and branches in the USA, China and elsewhere, and is accordingly training employees capable of performing globally. In fiscal 2012, it held Global Sales Meetings in Singapore and Malaysia, sending employees to its subsidiaries in these locations to foster their understanding and interest in its overseas ventures and get them to support the company's international business by building networks with its overseas sites. In fiscal 2013, NTT FACILITIES plans to hold further Global Sales Meetings in the USA and China.



● Occupational safety and health

Measures to eliminate accidents



The NTT Group has created a committee dedicated to eliminating serious accidents to check the measures taken by group companies that have suffered a serious accident to pinpoint causes, prevent recurrence and provide necessary advice and guidance, as well as oversee the groupwide implementation of a common accident prevention policy.

Both the NTT East Group and NTT West Group are working with partner companies to bolster their safety management structures, while the NTT FACILITIES Group holds a Safety Rally each year, and is in the process of introducing an industrial safety management system.

NTT East

To promote aerial work safety, in fiscal 2012 the NTT East Group focused on safety basics and the prevention of accidents by holding regular pole top practice sessions and organizing employees into small groups of 6 to 8 to hold safety issue brainstorming sessions aimed at raising employee safety awareness and cultivating a culture of safety.

Going forward, NTT East will focus on further raising employee safety awareness and eliminating on-the-job accidents and injuries by implementing measures tailored to the circumstances and attributes of specific workplaces.

In December 2011, it also deployed a Construction Occupational Health and Safety Management System (COHSMS)* and earned COHSMS certification to further raise its safety and health standards.



Checking safety procedures

***Construction Occupational Health and Safety Management System (COHSMS)**

Safety management system based on guidelines drawn up by the Japan Construction Occupational Safety and Health Association in line with the Guidelines on Occupational Safety and Health Management Systems issued by the Ministry of Health, Labour and Welfare in April 1999

NTT West

The NTT West Group promotes occupational safety across the Group by sharing information on accidents through its Safety Policy Review Committee to identify any issues in its everyday operations. It is also endeavoring to eliminate serious accidents through stressing worksite risk prediction, strengthening safety patrols, and employing risk visualization and the use of praise to raise employee safety awareness and bolster safety management.

In fiscal 2012, it designated June-July and November-December as Safety Measure Reinforcement Periods and implemented a range of safety measures. It also called for all employees to submit safety slogans, selecting the best for commendations and use on posters and block pad calendars that it distributed among employees to boost workplace safety awareness.



A safety drill

NTT FACILITIES

As a new initiative aimed at eliminating accidents, NTT FACILITIES has since July 2011 been steadily deploying F-OSMS, an occupational safety management system. Based on this management system, it also established a Disaster Prevention and Safety Planning Office as an organization to drive planned and sustained improvements in safety measures.

At the Safety Rally that it held in Tokyo's Yakult Hall in October 2011, NTT FACILITIES explained the goals and structure of its occupational safety management system to share the same awareness with all employees and prepare the ground for implementing F-OSMS across the whole NTT FACILITIES Group.



Safety Rally



● Preventing overwork

Group company measures for preventing overwork according to business



The NTT Group takes measures to protect the health of its employees and prevent them from overworking, including designating every Wednesday as a day when employees should refrain from working outside business hours. Group companies also actively implement their own measures for preventing overwork tailored to their particular businesses.

NTT Information Network Laboratory Group, for example, has designated monthly paydays as well as Wednesdays as no-overtime days. It also uses intercom broadcasts to encourage its employees to comply with this policy and wrap up their work within business hours on such days.

Using PC log management functions and other means to promote appropriate work habits



NTT DATA, NTT FACILITIES and NTT COMWARE make use of PC log management functions that record login and logout times to help promote appropriate work habits and prevent overwork.

NTT DATA

Preventing overwork is a constant challenge in the ICT industry. NTT DATA is striving to prevent overwork by setting itself the targets of keeping average hours worked per year to under 2,000 hours and if possible even less, and reducing the number of employees clocking over 2,300 hours.

In fiscal 2012, it reviewed work processes in conjunction with summer power saving measures, introducing new refreshment leave and anniversary holiday systems* and other measures for reducing work hours and getting all employees to take more time off. It also reviewed work hours in the light of employee computer login/logout records, and sought to promote reform by posting workplace reform success stories on the company intranet. As a result of these efforts, average annual hours worked per employee for fiscal 2012 came to 1,991 hours.

NTT DATA plans to promote comprehensive change in work styles by taking a flexible approach to time and space, while at the same time continuing to implement existing policies.

***Refreshment leave and anniversary holiday systems**

New leave systems introduced in October 2011. The refreshment leave system enables employees to take at least five consecutive days' holiday, including weekends and national holidays, once a year. The anniversary holiday system enables employees to select a specific anniversary beforehand to earmark as paid leave.



● Preventing overwork

NTT FACILITIES

In addition to using PC log management functions, NTT FACILITIES seeks to manage and reduce employee work hours by measures such as requiring employees to post color cards specifying anticipated overtime hours. In fiscal 2012, it further enhanced work hour management by strengthening the mechanisms for enabling various sections, in addition to those responsible for work management, to independently check employee PC logs.

It also helps employees to manage their health through ensuring strict compliance with rules designed to prevent impairment of health through overwork, and requiring employees working long hours outside normal business hours to consult with an industrial physician.

In fiscal 2012, total overtime rose slightly in the first quarter as a result of the Great East Japan Earthquake, but from the second quarter on, NTT FACILITIES' efforts to reduce overtime paid off, resulted in a year-on-year reduction in total overtime.

NTT COMWARE

NTT COMWARE endeavors to instill healthy work practices and reduce overtime both through using an employee PC log-based work hour management system and requiring employees to display cards detailing planned overtime on their desks, and through promoting communication tailored to the circumstances of each workplace and other creative measures.

It is also seeking to cultivate employee awareness through providing Web-based training on how to achieve a good work-life balance.

To further counter overwork and protect the health and safety of employees, it has configured its work hour management system to alert managers to instances of overtime that constitute overwork, and requires overworking employees to see industrial physicians and take other steps to lessen their work hours.

These efforts, together with synergy generated from summer power saving measures, resulted in a year-on-year decrease in the amount of overtime worked in fiscal 2012.

● Mental health care

Expanding mental health care programs



NTT Group companies are endeavoring to enhance the day-to-day management of the mental health of their employees through providing an increasing range of programs and services tailored to their respective businesses and type of work.

NTT

NTT holds regular training sessions and otherwise endeavors to nip mental health problems in the bud by providing its employees with both in-house and external mental health consultations services, mental health examinations and consultations for employees considered to be overworking.

In fiscal 2012, it provided a self-care e-learning program for non-managerial employees and both self-care and staff care programs for managers, and ensured that all employees were able to take these programs. It included exercises in communication with subordinates in its staff care program for managers to make the program more practical.

NTT East

In fiscal 2012, NTT East provided e-learning for non-regular employees as well as regular employees who joined the company in fiscal 2011 or later, in addition to working with its Health Management Center to implement mental health examinations and personal interviews with health management doctors, and provide guidance on workplace improvement.

It also set up Heart Call, a health consultation help line for employees and family members of employees working in areas affected by the Great East Japan Earthquake.



● Mental health care

NTT West

NTT West provides web-based mental health examinations as in the past, and has established a counseling center to help in the early detection and resolution of mental health problems. Based on Ministry of Health, Labour and Welfare guidelines*, it is also implementing various measures for employees with emotional problems that are preventing them from coming to work, including working with health management doctors to establish a structure for supporting the smooth return to work of such employees.

In fiscal 2012, it enhanced staff mental care by switching the means for distributing its manual on staff mental health management for managers from a printed pamphlet to an online manual that can be updated at any time. It also distributed information cards to all applicable employees and their families to raise awareness of the activities of the counseling center.

NTT Communications

NTT Communications provides its managers with organized "mental health keeper" training to enhance their abilities to watch over the mental health of their staff and respond appropriately to any personal problems. In fiscal 2011, almost all of its managers earned the Mental Keeper qualification.

Moving forward, NTT Communications plans to extend this program to its domestic group companies, and to develop counseling services for employees posted overseas.

NTT DOCOMO

NTT DOCOMO employs various means to help ensure the mental health of its employees, based on the Ministry of Health, Labour and Welfare's Guidelines for Promoting Mental Health Care in Enterprises.* Key policies include mental health examinations and stress checks for self-care, staff care training of various kinds for managers, and workplace inspections, post-health check follow-up and interviews with all employees by in-house occupational health personnel. These professionals also offer guidance to employees showing a tendency to overwork. NTT DOCOMO also provides employees with contacts for receiving mental health care counseling outside of the company.

*Guidelines for Promoting Mental Health Care in Enterprises

Drawn up by the Ministry of Health, Labour and Welfare in August 2000

NTT FACILITIES

NTT FACILITIES continued to provide an independent counseling center not directly connected to the company to offer counseling to employees and their families on matters related to their work, interpersonal relationships, private life and other personal issues. The center respects the privacy of employees seeking advice, and reveals no details of consultations to the company without the permission of the person concerned. In its in-house Welfare Newsletter, it encourages employees to make use of the counseling service. In fiscal 2011, it also started to provide e-learning to provide basic knowledge regarding mental health and help to prevent personal problems.

In fiscal 2012, in addition to existing measures, it continued to hold occupational stress checks for all employees, and held meetings between managers, industrial physicians and others to share views on alleviating stress in workplaces where stress appeared to be prevalent.

NTT COMWARE

NTT COMWARE provides all employees with guidance on health issues and educates them about the importance of maintaining good health through its health management center. It also distributes to all managers its Health Management Guidebook which brings together important information related to maintaining the health of employees. In fiscal 2012, it provided managers with mental health training, and held mental health checks (stress checks) for all employees. It also sent emails to all employees that encouraged them and their families to make use of an independent counseling service for seeking help on matters related to their work, interpersonal relationships, private life and other personal issues.



● Citizenship activities: basic policy and its implementation

Implementing citizenship activities in environmental conservation and five other areas



All NTT Group company personnel and their families as well as former NTT employees and people from local communities actively participate on a sustained basis in our citizenship activities as members of Team NTT.

In line with the Team NTT communication pledge set forth in our CSR Charter, we carry out citizenship activities in the following six areas: environmental conservation, social welfare, education and cultural promotion, local community development and dialog, international exchange activities and sports promotion.

Particularly where environmental conservation is concerned, since fiscal 2010 we have been implementing groupwide environmental contribution activities that involve the participation of employees under the slogan "Green with Team NTT".

We drew up groupwide priority policies in fiscal 2011, and in 2012 implemented Operation Clean Environment local community cleanups, the collection of PET bottle plastic caps for the Ecocap Movement, the elimination of disposable chopsticks from employee cafeterias and plastic shopping bags from kiosks, and employee hands-on environmental education activities. The annual Mt. Fuji Cleanup and greening of building rooftops that were priority policies of fiscal 2011 were in fiscal 2012 combined respectively with Operation Clean Environment and employee hands-on environmental education activities to be continued as closely related policies. As a result of setting groupwide quantitative targets for top priority policies and calling for the cooperation of all group companies, in fiscal 2012 we managed to surpass both fiscal 2012 targets and fiscal 2011 results for PET bottle cap collection and Operation Clean Environment by a considerable margin.

We also focused in fiscal 2012 on saving electricity to respond to the risk of nationwide energy shortfalls in the wake of the Great

East Japan Earthquake. In addition to promoting Cool Biz and Warm Biz dress codes in summer and winter respectively, we called on employees to save electricity in their homes.

In fiscal 2013, we will continue to focus across the Group on the collection of PET bottle caps, Operation Clean Environment local community cleanups, energy conservation measures and employee hands-on environmental education activities as priority policies.

Green with Team NTT is one of the three approaches set forth in THE GREEN VISION 2020, the NTT Group vision for the environment announced in November 2010. We will continue to involve our employees in efforts to further reduce environmental impacts. Details regarding specific initiatives can be found under "Green with Team NTT" in the "Communication between people and the global environment" section of this report.

Green with Team NTT priority policy progress status

Policy	Fiscal 2012 target	Fiscal 2012 result
PET bottle caps collected	28,200,000	31,880,000
Elimination of disposable chopsticks from employee cafeterias	—	Implemented at 319 cafeterias
Elimination of plastic shopping bags from kiosks	—	Implemented at 62 kiosks
Employee hands-on environmental education activities	—	4,551 participants for the year
Operation Clean Environment (local community cleanup) participants	100,000	118,195



The NTT 3/11 Recovery Forest Project, a hands-on environmental education activity (tree planting) for employees



● Citizenship activities: basic policy and its implementation

Support for citizenship activities



Based on the belief that participation in citizenship activities can help to broaden the mind, NTT Group companies are implementing an increasing range of policies to support employee citizenship activities, informing employees of support programs, and commending citizenship activities carried out under such programs. Other programs include a Matching Gift Program under which group companies match donations collected independently by employees, and a Volunteer Gift Program under which group companies donate goods to facilities etc. where employees are engaged in voluntary citizenship activities.

Under the fiscal 2012 Matching Gift Program, NTT matched funds raised from employees by a voluntary employee welfare organization for donation to a social welfare corporation based in Kiyose City, Tokyo.

Key programs in support of volunteer activities

Program	Details
Volunteer Gift Program	This program provides goods from the volunteer's company to facilities etc. where the volunteer has been active over a long period of time.
Matching Gift Program	Under this program, NTT Group companies support employees' fund-raising and charity activities by matching donations made by employees.
Volunteer Leave Program	This program enables employees to take extended leave for volunteer activities or other purposes in line with life design plans.

● Examples of citizenship activities

**(Welfare)
Dementia support**



NTT West Home Techno Kyushu (NTT HOMETECHNO Kyushu Branch from July 1, 2012) conducts activities to gain a correct understanding of dementia and watch over people suffering from dementia and their families under the Ministry of Health, Labour and Welfare's 10 Year Campaign to Understand Dementia and Build Community Networks.

In fiscal 2011, 12 employees at the Hitoyoshi Service Center of the Kumamoto Sales Office took a dementia support training course organized by the city of Hitoyoshi, and qualified as dementia supporters. Leveraging the nature of their work, almost all of which involves house to house calls, the supporters involved themselves in watching over elderly people, asking after them, passing on information, and such like. In fiscal 2012, the whole company got behind the campaign, and 649 employees, including head office employees, took the course and qualified as dementia supporters. This number is slated to grow even larger in fiscal 2013.



Dementia support training course class



● Examples of citizenship activities

(Education) Communicating the wonder of science and technology



The NTT Information Network Laboratory Group has long been involved in educational support for children (whose interest in science has declined in recent years in Japan), and activities to contribute to local communities in the Musashino district of Tokyo in which one of its laboratories is based.

For example, it holds summer vacation interactive science classes for children to communicate how fun science can be through making things and carrying out experiments. It also participates every year in the Musashino Science Festa organized by the city of Musashino, putting great effort into creating exhibits that will appeal to children and enable them to learn about NTT research achievements.

The NTT History Center of Technologies, which is housed within the NTT Musashino Research and Development Center, also seeks to whet the creative urges of the next generation by exhibiting a wide range of artifacts from the historical roots of telecommunications in Japan to recent technologies developed by the NTT Group. From July 2010, it has opened its doors to the public on every Thursday afternoon so as to make its historical telecommunications technology assets available to a wider audience.

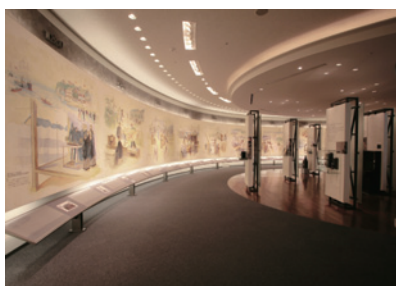

NTT History Center of Technologies



Interactive science class for children

(International) Co-sponsoring a Japanese-Chinese speech contest in China



To help to further foster understanding between China and Japan, NTT DOCOMO's Beijing Representative Office co-sponsored the 21st Voices of Japan-China Friendship: Japanese/Chinese Speech Contest held at Tianjin Foreign Studies University in April 2012, and the nationwide 7th Voices of Japan-China Friendship: All China Japanese Speech Grand Champion Contest. At the nationwide contest, 20 representatives selected from 460 universities in China gave impassioned speeches on the theme of "Indomitable Courage" to an audience of over 300 to compete for the honor of becoming No.1 in China.

The Beijing Representative Office has co-sponsored the Japanese/Chinese Speech Contest every year since 2001, a contribution that was recognized at this year's contest with the presentation of two special awards.



Commemorative photo taken after the award ceremony



● Examples of citizenship activities

(Environment) Solar-powered water purification system “Solar UFO” installed in Fukuoka



In April 2011, NTT FACILITIES installed “Solar UFO”, a solar-powered water purification system, at a moat in Maizuru Park in the city of Fukuoka. Solar UFO is a floating disc-shaped device five meters in diameter, equipped with photovoltaic cells on its upper surface, and filtering and aeration systems below that use the solar power generated by the photovoltaic cells to purify the pond’s water. This was the second installation nationwide, following Osaka.

Solar UFO purifies water during the day, and lights up at night to create a magical atmosphere with a LED system fueled by solar power generated during the day. Maizuru Park is a very popular park, and Solar UFO added to its scenic appeal while helping to keep the moat water clean. NTT FACILITIES plans to relocate this and another Solar UFO unit to Koshigaya Lake Town and Nagoya University in fiscal 2013.



Solar UFO in Maizuru Park, Fukuoka

(Environment) PET bottle cap collection



The NTT Group selected the collection of PET bottle plastic caps for the Ecocap Movement, an activity that group companies had carried out independently since 2008, as a groupwide policy and intensified collection efforts from fiscal 2011.

By recycling PET bottle caps, the Ecocap Movement reduces CO₂ emissions from waste incineration, and uses part of the income generated by recycling the caps to provide vaccinations for children in developing countries.

In fiscal 2012, the NTT Group exceeded its target for the year of 30 million caps, collecting a total of 31.94 million caps that represents emissions reductions of 252 t-CO₂ and vaccinations for 39,926 children.



Mariko Kawaguchi

Senior Analyst, Management Strategy Research Department, Daiwa Institute of Research Ltd.

Ms. Kawaguchi joined Daiwa Securities Co. Ltd. in 1986 after completing a Master's degree in public finance and environmental economics at Hitotsubashi University's Graduate School. She transferred to Daiwa Institute of Research Ltd. in 1994, and after conducting corporate credit research, served in 2010-2011 as General Manager for CSR in Daiwa Securities Group Inc.'s Corporate Communication Department. She returned to Daiwa Institute of Research in July 2011, and became a senior analyst in April 2012, focusing on environmental management, CSR and socially responsible investing.

Chief Executive and Secretary General, Social Investment Forum Japan. Trustee of the Sustainability Forum Japan, Member of the EcoAction 21 Auditor Certification Committee, Member of Ministry of the Environment's Environmental Businesswomen, Member of Tokyo Metropolitan Government's Environmental Committee.

Co-author of *Introduction to Socially Responsible Investing*, *CSR: Raising Corporate Value* (both in Japanese, pub. Nikkei) and other works

In the past, CSR generally referred to management areas such as compliance, environmental management system building and the use of PDCA cycles, but over the past four or five years, priority has shifted to the leveraging of CSR as a management strategy aimed at contributing to the resolution of social issues through applying core competences, and raising corporate value as a result. In this sense, I think that the NTT Group, a huge enterprise with a workforce of over 220,000 and 772 consolidated subsidiaries, is setting an excellent example of CSR best practice in the ICT industry through its presentation — in combination with a broad range of specific activities introduced in the detailed Web edition — of its leader's clear statement of a CSR philosophy aimed at leveraging ICT to address social issues, its establishment of eight CSR Priority Activities in the four areas of communication between people and their communities, communication between people and the global environment, safe and secure communication, and Team NTT communication, and its setting of quantitative indicators.

Telecommunications infrastructure tends to go unnoticed until something happens, and so the Great East Japan Earthquake served to remind people of the importance of a solid infrastructure, and the breadth and depth of today's ICT networks. It also raised awareness of the vulnerability of communications networks and other related issues. NTT has reported here that it has responded both by endeavoring to build even more disaster-resistant networks and expand and improve its disaster services, and by strengthening its research and development activities. Since earthquakes, drought, floods and other natural calamities are occurring with increasing frequency worldwide, NTT's initiatives deserve high marks for the way they match today's needs.

The special feature, which introduced projects such as e-learning in Africa, a pilot project to jointly test remote healthcare technology in Japan, development of educational systems for hearing-impaired children, DC power supply systems and remote monitoring services, was fascinating, and brought home to me the immense breadth of social issues that ICT can help to address. I also thought that the roundtable video conference between key people in group companies involved in business in China was an

interesting example of how ICT companies can help reduce the environmental and monetary costs of business travel. The outline of the roundtable carried in the detailed Web edition provided a glimpse of the efforts of people at the front line to contribute to the development of Chinese society as they do business, through the transfer of advanced Japanese environmental and safety monitoring technologies, and the implementation of financial system, logistics and other projects of great potential benefit to society, while at the same time maintaining a diverse workforce in China, where economic growth has also resulted in serious environmental problems and income disparities. I felt that the roundtable would also have been a valuable experience from the perspective of driving all kinds of BoP businesses.

However, even as its value to society continues to grow, ICT also has negative impacts that cannot be ignored. ICT is expected to reduce the environmental impacts of society through the spread of smart devices and such like, but as mentioned in the talk with Oya-san, the NTT Group accounts for a full 1% of Japan's electricity consumption. As one of Japan's leading companies, I think that NTT should focus even more resources on the development of energy-efficient IT equipment, green buildings, renewable energy and the conservation of biodiversity. It also needs to address social issues such as the safety of electromagnetic waves, Internet and computer game addiction among young people worldwide, and the exposure of children to Internet threats, a major concern of parents. I know of course that NTT is already involved in research and educational activities to address such problems, but these efforts have not yet left their mark on society. Also, tools of the modern age such as cars, electrical appliances and PCs have made our lives very convenient, but our walking abilities, vision, hearing, stamina, patience, dexterity and other abilities have suffered as a result. ICT is the ultimate provider of convenience in the way it enables us to share information across both time and space, and this report demonstrates that NTT is making great efforts to cultivate the positive social impacts of ICT. Moving forward, I would like to see it do even more to pinpoint and highlight negative impacts, and to actively reduce or remedy those impacts as an ICT industry leader.

Our response

We have endeavored to make this report as readable as possible through writing in plain, natural language, and using abundant illustrations and photos. In the special feature on the theme of addressing social issues through ICT, we introduced initiatives that we are implementing as a global ICT group throughout the world, and also focused on R&D aimed at addressing energy and environmental issues, providing details of some major achievements.

Ms. Kawaguchi praised our establishment of eight Priority Activities under four CSR goals and setting of quantitative indicators. As a business group that bears responsibility for maintaining communications infrastructure, we also take particular pride in Ms. Kawaguchi's comment that "NTT's initiatives deserve high marks for the way they match today's needs" with respect to our research and development efforts and business policies aimed at building more reliable and disaster-resistant networks and services in the wake of the Great East Japan Earthquake.

Ms. Kawaguchi also remarked that while we are contributing to the resolution of a very wide range of social issues through the utilization of ICT, our groupwide efforts to counter the negative impacts of ICT "have not yet left their mark on society." We much appreciate this valuable opinion, and will put even greater priority on our efforts in this direction as we implement the NTT Group's CSR policies.

Furthering our efforts to contribute to society through ICT that comprise the basis of our CSR also requires that we focus not only on bringing the benefits of ICT to society, but also on mitigating any negative impacts of ICT as an aspect of fulfilling our social responsibility to help create a safe, secure and prosperous society. We intend to further enhance ongoing initiatives to reduce the environmental impacts of both our own business activities and those of society as a whole, R&D and services to maintain and improve information security, and services and educational activities to ensure safe and secure use of ICT by children and elderly people. We will also pinpoint impacts on environmental and social issues, and endeavor to remedy them, while at the same time conducting groupwide discussions on how to ensure that such efforts leave their mark on society, and applying our findings to our future initiatives.

Ms. Kawaguchi described our efforts as "an excellent example of CSR best practice in the ICT industry." We will do all in our power to fulfill our social responsibility as the NTT Group and ensure that we live up to her words. We will continue to put priority on communication with our stakeholders as we endeavor to contribute to the sustainable development of society moving forward.

CSR Promotion Office
NIPPON TELEGRAPH AND TELEPHONE CORPORATION

Reader feedback

Results of NTT Group CSR Report 2011 questionnaire survey

We would like to thank all those throughout the world who responded to our questionnaire both by post or fax, and via our website. We will make use of your valuable opinions in the planning of future CSR activities and reports.

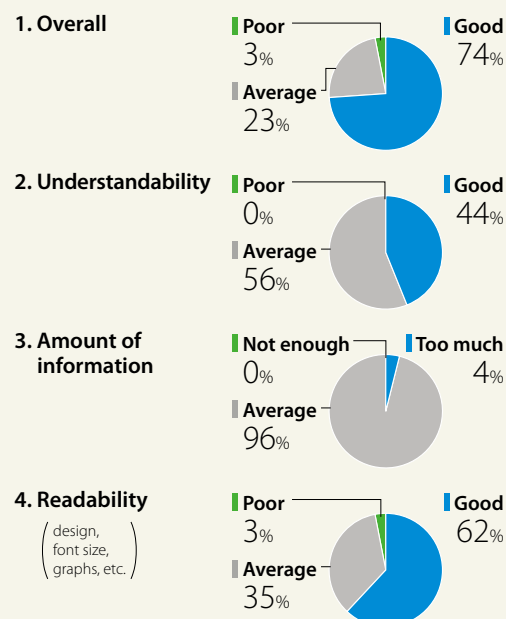

Representative opinions

Ever since the Great East Japan Earthquake, I've worried about the vulnerability of the telecommunications infrastructure that adds so much convenience to everyday life. I couldn't use either fixed line or mobile phone for hours, which made things very difficult. As such, I'm all for creating disaster-resistant telecommunications infrastructure on any scale.

Considering the fact that Twitter proved very useful when mobile networks went bust, I'd like to see NTT work with other carriers to provide a system other than mobile voice communications for the stable sharing of information in emergencies.

The Disaster Emergency Message Dial and Disaster Message Board services provided much-needed reassurance. At the same time, the disaster made me realize how dependent we are now in present-day Japan on phones and other easy means of communications.

I think that NTT is in the best position to drive the deployment of ICT in educational facilities, and I have high hopes for its efforts in this area.

Japan's population will continue to age, and so I think that providing remote health consultations services for areas with a shortage of doctors is a very worthwhile initiative.

I've always been interested in endeavors to create a more eco-friendly society, and I'm even more interested now after the Tohoku earthquake. I would love to see networks being leveraged to create a low carbon society.

Contact information

3-1, Otemachi 2-chome, Chiyoda-ku, Tokyo 100-8116, Japan
E-mail: csr@ml.hco.ntt.co.jp

